

Code of Management Practice

Guide for Commercial Imaging



Recommendations on Technology,
Equipment and Management Practices for
Controlling Silver Discharges from
Facilities that Process Photographic Materials

The Silver Council

The Silver Council

The Silver Council is a national group focussed on the environmentally sound management of silver derived from the processing of photographic images. The Silver Council is supported by the photographic chemical and equipment manufacturers and represents more than 360,000 users. The purpose is to encourage communications between the regulatory and regulated communities, to support scientific research, and to share current scientific, technical and economic information so that the common goals of pollution prevention, recycling, water conservation, and compliance can be met.

The Silver Council

550 Mamaroneck Road
Suite 307
Harrison, NY 10528-1612
Phone: (914) 698-7603
Fax: (914) 698-7609

This document may be reproduced in its entirety without permission for distribution at no charge to commercial imaging facilities.

© 1997 by National Association of Photographic Manufacturers, Inc.

The Commercial Imaging Guide to the Code of Management Practice

The Commercial Imaging Guide to the Code of Management Practice is a set of recommended operating procedures designed to reduce both the amount of silver and the overall volume of photographic processing solutions discharged to the drain. This guide has been written for pre-press operations, micrographics and other commercial imaging facilities.

Limitations of the Commercial Imaging Guide to the Code of Management Practice

The Commercial Imaging Guide to the Code of Management Practice **does not** supercede existing local regulations. **Use this Guide only after the local municipality has adopted the Code of Management Practice for Silver Dischargers (CMP) into regulation.** Use of this Guide where the CMP has not been adopted may cause the commercial imaging facility to be out of compliance with local regulations. Before using the Guide, each commercial imaging facility should check with the local government agency to determine its regulatory requirements. For more information contact The Silver Council.

Acknowledgements

Many individuals representing the commercial imaging industry have contributed to the Commercial Imaging Guide to the Code of Management Practice. This Guide is the direct result of their participation in the committee process. We gratefully acknowledge all of these contributions.

The participants volunteered their time and expertise, thus ensuring this Guide provides an approach written *by* commercial processors. Our thanks to each of these people and their companies. Special thanks go to Ms. Susan Borea, Agfa Division, Bayer Corporation, Mr. Dan Sinto, Anitec and Mr. Thomas Purcell, The Silver Council for their assistance to this publication. This project was funded by The Silver Council.

Association of Graphic Communications

Environmental Conservation Board for the Graphics Communication Industries (ECB)

Envision Compliance Ltd.

Graphic Arts Technical Foundation (GATF)

The Silver Council

Agfa Division, Bayer Corporation

Anitec

Eastman Kodak Company

FUJIFILM America, Incorporated

Ilford Photo

Imation Corporation

Konica Corporation

National Association of Photographic Manufacturers (NAPM)

Photo Marketing Association International (PMAI)

Table of Contents

- 1.0 Introduction** 1
 - 1.1 Regulating Silver 2
 - a. Concentration-based Limits 2
 - b. Performance-based Limits 3
 - What’s the Concern with Silver? 3
 - 1.2 Implementing the Code 4

- 2.0 Determining the Category** 5

- 3.0 Small Commercial Imaging Facility** 6
 - 3.1 Compliance Options 6
 - 3.2 Equipment Configurations 6
 - 1. One or Two Chemical Recovery Cartridges 7
 - 2. Terminal electrolytic Unit Followed by a
Chemical Recovery Cartridge 8
 - 3. Off-Site Management 9

- 4.0 Medium Commercial Imaging Facility** 10
 - 4.1 Compliance Options 10
 - 4.2 Equipment Configurations 10
 - 1. Terminal electrolytic Unit Followed by a Chemical
Recovery Cartridge 11
 - 2. In-line electrolytic Unit Followed by a Chemical Recovery Cartridge 12
 - 3. Two or More Chemical Recovery Cartridges 13
 - 4. Off-Site Management 14

- 5.0 Large Commercial Imaging Facility** 15
 - 5.1 Compliance Options 15
 - 5.2 Equipment Configurations 15
 - 1. Terminal electrolytic Unit Followed by Two or More Chemical
Recovery Cartridges 16
 - 2. In-line electrolytic Unit Followed by a Chemical Recovery Cartridge 17
 - 3. Off-Site Management 18

Table of Contents

6.0	Pollution Prevention	19
6.1	Put a Team Together	20
	a. Management Activities	20
	b. Staff Activities	21
	P2 Team Checklist	22
6.2	Review Your Options	23
	a. Management Practices	23
	Preventive Maintenance	23
	Process Control	23
	Inventory Control	24
	Spill Response Planning	24
	Good Housekeeping	24
	Safety and Security	25
	Management Practices Checklist	26
	b. Equipment Modifications	28
	Squeegee Rollers	28
	In-line Silver Recovery	28
	Stand-by Wash	28
	Equipment Modifications Checklist	29
	c. Process Modifications	30
	Low Replenishment Chemicals	30
	Solution Regeneration and Reuse	30
	Water Reuse and Recycling	30
	Dry Chemicals and Automated Mixing	30
	Process Modifications Checklist	31
	d. Solid Waste	32
	Solid Waste Checklist	33
6.3	Develop a P2 Plan	34
	Screening Your Options	34
	Example Worksheet for Screening Options	34
	Point System	35
	Writing the P2 Plan	35
	Example Pollution Prevention Plan Worksheet	35
6.4	Put the Plan in Place	36
6.5	Track Your Results	36
	Example Worksheet for Evaluating P2	36
	Spread the Word	37

Table of Contents

Appendices

Appendix A	Glossary of Terms	38
Appendix B	Electrolytic Silver Recovery	41
Appendix C	Chemical Recovery Cartridges	44
Appendix D	Off-Site Silver Management	47
Appendix E	Evaporation and Distillation	50
Appendix F	Ion Exchange	51
Appendix G	Testing for Silver	53
Appendix H	Forms	55
	Sample Spill Contingency Plan	56
	Worksheet for Screening Options	57
	Pollution Prevention Plan Worksheet	58
	Worksheet for Evaluating P2	59
	Processor Log Form	60

1.0 Introduction

Photo processing effluent is a by-product of processing film. After silver recovery, this effluent is generally discharged to the drain where it goes to the publicly owned treatment works (POTW) for treatment and eventual release back to the environment. Processing solutions must not be discharged to a septic system.

Silver is the component of film and paper that makes it possible to form an image. While it's not an ingredient of fresh solutions, during processing the silver is removed from the film and paper and goes into the solutions. Silver should be recovered from silver-rich solutions before they are discharged to the drain because:

- silver is a non-renewable resource,
- some sewage treatment plants (POTWs) and states restrict the amount of silver that can be discharged, and
- silver has economic value.

A silver-rich solution is a solution that contains sufficient silver that cost-effective recovery can be done either on-site or off-site. Silver-rich solutions include fixers and may include water from recirculated washwater systems.

Effective silver recovery requires equipment that is appropriate to the size and activities of the commercial imaging facility. It also requires implementing a sound preventive maintenance program for silver recovery equipment.

Providing you with this information is the primary focus of the *Commercial Imaging Guide to the Code of Management Practice*.

The principal elements of the Commercial Imaging Guide to the Code of Management Practice is a set of recommended operating procedures designed to reduce both the amount of silver and the overall volume of processing solutions discharged to the drain.

The other element of the Guide is voluntary pollution prevention. In addition to recovering silver efficiently, commercial imaging processors should be concerned with minimizing the amount of waste they create. Waste solutions are literally money down the drain. In cases where the solutions can't be discharged to drain, such as when the processor discharges to a septic system, it costs money for off-site disposal. That's why it makes sense to minimize waste in the first place. The second half of the guide details several activities a commercial imaging processor can **voluntarily** undertake to reduce waste and save money.

The *Commercial Imaging Guide to the Code of Management Practice* is a guide of industry recommended practices. It is **NOT** a legal requirement. It was written by people just like yourselves—people who manage imaging operations.

The Guide takes the guesswork out of determining the specific silver recovery configurations and preventive maintenance activities you need. Terms used throughout this Guide are defined in the Glossary of Terms (Appendix A).

1.1 Regulating Silver

Silver discharges can be regulated or controlled by two different approaches. The first approach establishes limits on the concentration or total amount of silver in the wastewater. The second approach requires suitable treatment be applied before the wastewater is discharged to the drain. These categories are “concentration-based” or “performance-based,” respectively.

a. Concentration-based limits

The traditional means of restricting silver is through concentration-based numerical limits in the state law or the city sewer ordinance. For example, silver may be restricted to 4 parts per million (ppm).* This means that for every million parts of effluent, there can be *no more* than four parts of silver.

Concentration-based limits have been shown to be a poor way to regulate commercial imaging operations for several reasons:

1. Our industry strives to conserve water through standby washing, wash water recycling and lower replenishment rates for process chemicals. As we use less water, the concentration of silver in the effluent **increases. Concentration-based limits, therefore, actually penalize those who practice water conservation.

2. Municipal and state sewage treatment authorities ideally develop pretreatment limitations by comparing wastewater coming into the sewage treatment plant and the treated water leaving the plant. The discharge of treated wastewater must meet limits set by the sewage authority/EPA to avoid impact on the water quality of the receiving body of water. Local development of pretreatment limitations has resulted in widely varying and often unrealistic restrictions across the country.
3. The sampling point used to determine whether or not a limit is being met is determined by the local sewer authority. It may be the property line manhole, a point where all process wastewater is combined or at the point of generation. This introduces additional variation from city to city.
4. Our industry’s ability to recover silver cost-effectively is dependent upon the equipment available in the marketplace. Restrictions in some jurisdictions are so stringent they can not be met with any cost effective technology available.



b. Performance-based limits

Performance-based limits are spelled out as a percentage of the silver that must be recovered from discharged materials.

* ppm is the same measurement as milligrams per liter (mg/L).

** Effluent is the liquid waste generated from the processing of photographic material.

These limits provide environmental protection while taking into consideration the amount of silver-rich solutions generated by the imaging operation and the capability of the technology (equipment) available.

The Code of Management Practice places commercial imaging facilities into one of four categories and provides specific silver recovery equipment recommendations for each category. The category could vary for each processor in your facility. For example, there may be a processor that runs only a few films per day. This machine would fall into the small category. In the same shop, there may be a busy processor that runs numerous films per day and would fall into the medium or large category.

If the POTW were classifying your facility, it might take into consideration all the process effluent produced per day in the entire facility. For our purposes that's not very helpful. It could easily result in requiring an extensive silver recovery system on every processor—even one on which only a few films per day are processed. If you have this type of situation in your facility, you may need to discuss this with your POTW when it comes to categorizing your equipment.

The exception is in facilities where silver recovery operations are centralized. In these cases, where fixer from many processors are collected and desilvered in a central location, the category is based on a total volume of fixer and processing effluent produced at the centralized treatment site.

What's the Concern With Silver?

We wear silver jewelry, eat off silverware and carry silver fillings in our teeth. Then why is the silver in commercial imaging processing solutions regulated? The answer has to do with the different forms silver can take. The metallic silver that we use in eating utensils and jewelry is nontoxic. But some forms of silver can be very toxic to aquatic organisms. In fact, years ago, silver was used as a biocide in wastewater treatment. Even today, silver nitrate is sometimes added to the eyes of new infants in order to kill bacteria.

Because the silver ion is highly reactive, it quickly and easily complexes with materials in the environment such as sulfides and chlorides, to yield compounds with little or no toxicity. This means that silver rarely occurs in ionic or noncomplexed forms. The silver found in used fixer, for example, is in the form of silver thiosulfate, a nontoxic form.

While there is general agreement among regulators that it's the ionic form of silver that's most toxic, there's no accurate and repeatable analytical test method to measure the ionic species. Therefore, regulations are based on total silver, with no differentiation between ionic and complexed forms of silver.

So silver discharge regulations impact all pre-press processors. While individual dischargers may have little impact on the POTW, collectively, commercial imaging facilities discharge a significant amount of silver.

The four categories of film processors, as identified in the Code of Management Practice are as follows:

- A **small** commercial imaging facility is one that produces less than two gallons per day of silver-rich solutions *and no more than* 1000 gallons per day of total process effluent. Small facilities must recover silver to at least 90 percent efficiency. **90%**
- A **medium** commercial imaging facility is one that produces less than 20 gallons per day of silver-rich solutions and no more than 10,000 gallons per day of total process effluent. Medium facilities must recover silver to at least 95 percent efficiency. **95%**
- A **large** commercial imaging facility is one that produces more than 20 gallons per day of silver-rich solutions and no more than 25,000 gallons per day of total process effluent. Large facilities must recover silver to at least 99 percent efficiency. **99%**
- A **significant industrial user** (SIU) is one that discharges more than 25,000 gallons per day of total effluent.* SIUs have no set percentage recovery efficiency as each SIU is individually permitted by the city.

Through the use of this guide, the commercial processor, together with the local agency can cooperatively regulate silver discharges to sewer.

* The EPA defines a significant industrial user as a facility that discharges an average of 25,000 gallons per day or more of *process wastewater* to the publicly owned treatment works (POTW) (excluding sanitary, noncontact cooling and boiler blowdown waste water). Individual municipalities are free to use a more stringent definition. (40 CFR 403.3 (t)(ii))

This Guide offers a uniform approach to regulation from city to city. Most existing restrictions are unachievable given today's technology and the industry goal of conserving water.

Performance-based limits are realistic, given the technology currently available to commercial imaging operations. Performance-based limits that are uniform across the country would allow the industry to self-regulate.

Performance-based limits are the best way to ensure environmental protection while providing economic incentive to the commercial imaging operation.

1.2 Implementing the Code

Who is responsible for ensuring this performance-based silver management program is implemented?

In a medium or large operation, the responsible person is most likely the film processing manager. While the technical service or even the processor operator may be assigned the job of putting certain aspects of the CMP in place, the final responsibility rests with management. That responsibility cannot be delegated. Even if an outside contractor services the processors and silver recovery systems, the responsibility stays with the facility manager.

In a small facility, the owner is most likely the responsible person. The same holds true in this situation; while a technician or assistant may undertake part of the duties of silver management and pollution prevention, the final responsibility lies with the person in charge.

2.0 Determining the Category

The first step is to determine which of the four categories best describes your facility: small, medium, large or significant industrial user (SIU). Remember, if you have centralized silver recovery, you must consider the amount of fixer produced throughout the entire facility, rather than by individual processing machines.

Step 1

For a specific processor (or central silver recovery site), calculate or measure the amount of fixer overflow produced in *one* day. For a more accurate estimate, average the fixer overflow over several days. Make sure you are using typical processing volume days.

Step 2

On the chart below, locate the *Fixer Overflow* column. Look down that column and find the amount of fixer overflow you estimated in step 1. Identify the processor category size and the silver recovery efficiency which corresponds to this volume.

Example: If in step 1 you estimated that a given processor produced 6 gallons per day (GPD) of fixer, that processor would be categorized as medium and the silver recovery efficiency required would be 95 percent.

Note: If your facility produces in total more than 20 gallons per day (GPD) of fixer then you must also consider the total amount of process wastewater produced. If the total process wastewater volume is less than 25,000 GPD then you can consider each processor individually. If it is greater than 25,000 GPD you are considered a Significant Industrial User and need to talk to your POTW.

Step 3

If you have more than one processor, use the Processor Log Form in Appendix H to list each processor, the category size, and the required silver recovery efficiency.

Category	Fixer Overflow	Wastewater Volume	% Silver Recovery
Small	< 2	<1000	90%
Medium	>2 but <20	<10,000	95%
Large	> 20	<25,000	99%
SIU	-	>25,000	by permit

all fixer and wastewater measurements are in gallons per day, GPD

3.0 Small Commercial Imaging Facility

A small commercial imaging facility is one that produces less than 2 gallons per day of silver-rich solution. Small facilities must recover silver to at least 90 percent efficiency.

If you are a small facility, you have four practical options for compliance (achieving a 90 percent removal). These can be configured in several ways, discussed below.

3.1 Compliance Options

The following silver recovery options are recommended for recovering at least 90% of the silver from silver-rich solutions:

1. one or two chemical recovery cartridges (CRCs) with manufacturer specified flow control,* or
2. terminal electrolytic unit followed by a chemical recovery cartridge (CRC) with manufacturer specified flow control, or
3. off-site management, or
4. alternative technology providing at least 90 percent silver recovery.

* Facilities that generate less than 0.5 gallons per day of silver-rich solutions need only one CRC. Due to the low volume, a second CRC would oxidize and channel by the time the first CRC was exhausted resulting in no additional silver recovery.

3.2 Equipment Configurations

In this section for small facilities, we'll review typical silver recovery equipment configurations for each of the compliance options. Detailed information is available in the appendices.

We'll also describe the testing methods and procedures to use with the equipment to verify that it is recovering at least 90 percent of the silver.

Finally, we'll show you samples of simple silver recovery logs to use for recording the results of the testing.

For detailed information about a specific type of silver recovery equipment, how it works, and preventive maintenance recommendations, refer to:

Appendix B Electrolytic Silver Recovery
Appendix C Chemical Recovery Cartridges
Appendix D Off-Site Management

1. One or two chemical recovery cartridges (CRCs) with manufacturer specified flow control

How it works

In this configuration, the silver-rich overflow from the processor (A) is directed to an holding tank (B - optional). Next, it is metered (C - optional) at a fixed rate through the chemical recovery cartridges (CRCs) set up in series (E and G). In this diagram two CRCs are shown. Once the solution exits the last cartridge in series (H) at least 90 percent of the silver has been recovered and the solution can be discharged to the drain (I).

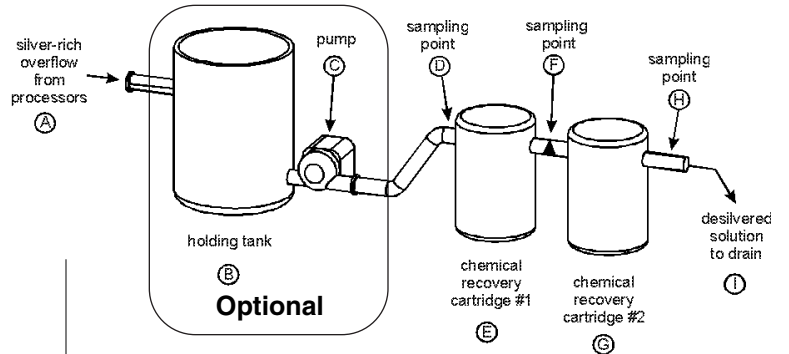

- To verify the percent efficiency of the system, use an analytical laboratory to test the solution *once every year*, from two locations:
 - before the first CRC at (B)
 - after the last CRC at (H)

Testing methods for silver recovery efficiency
There are two types of testing methods you must use:

- once each week**, silver estimating test papers or another method of approximating silver concentration must be used to indicate whether the system is working (if the paper shows any change in color, the system is not working), and
- once every year**, highly accurate analytical laboratory testing such as atomic absorption (AA) or inductively coupled plasma spectroscopy (ICP) must be used. Use an outside service for analytical testing.

Testing procedures

- To indicate whether the system is working, check the solution *weekly* with silver estimating test papers at two locations:
 - after the first CRC at (F)
 - after the last CRC at (H)

See Appendix G for more information about testing for silver.

Testing records

- All test results must be recorded in a silver recovery log. See the examples below. Check with the publicly owned treatment works (POTW) to find out how long to keep records on file.

Silver Recovery Log		
Date	Weekly Effluent Check*	
	CRC #1	CRC #2
7/1/96	P	P
7/8/96	P	P
7/15/96	F	P

* Pass (P) = no color, Fail (F) = color

When the weekly check indicates cartridge failure, refer to the equipment manual for the manufacturer's recommendations.

Silver Recovery Log (ppm)			
Date	Annual Test		% Recovery
	Influent	Effluent	
7/1/96	2800	280	90%
7/1/97			
7/1/98			

To obtain the percent recovery, use the following formula:
 $100 - (\text{effluent} \times 100 \div \text{influent})$.

2. Terminal electrolytic unit followed by a chemical recovery cartridge (CRC) with manufacturer specified flow control

How it works

In this configuration, the silver-rich overflow from the processor (A) is directed to the electrolytic unit (B). When sufficient silver-rich solution has accumulated, the electrolytic unit begins to desilver the solution. When the batch is completed, the partially desilvered solution is pumped out of the electrolytic unit (C) into the holding tank (D-optional). From here, it is metered (E-optional) at a fixed rate through the chemical recovery cartridge (G). Once the solution exits the cartridge (H) at least 90 percent of the silver has been recovered and the solution can be discharged to the drain (I).

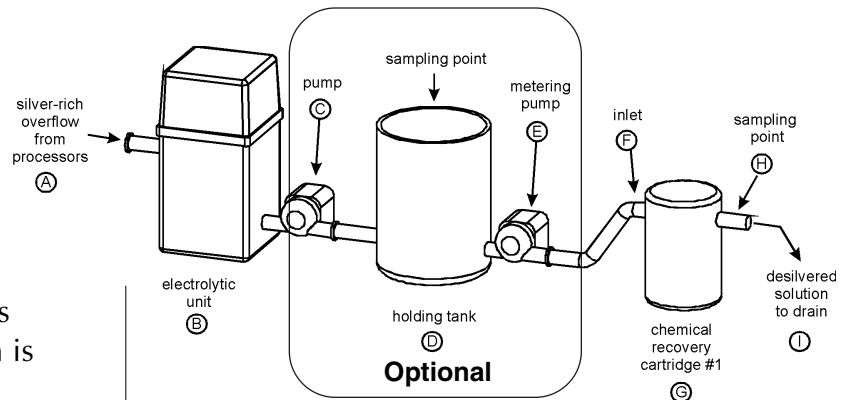

with silver estimating test papers at two locations:

- after the electrolytic unit at (D)
- after the CRC at (H)

- To verify the percent efficiency of the system, use an analytical laboratory to test the solution *once every year*, from two locations:
 - before the electrolytic unit at (A)
 - after the CRC at (H)

Testing methods for silver recovery efficiency

There are two types of testing methods you must use:

- **once each week**, silver estimating test papers or another method of approximating silver concentration must be used to indicate the system is working, (if the paper shows any change in color, the system is not working), and
- **once every year**, highly accurate analytical laboratory testing such as atomic absorption (AA) or inductively coupled plasma spectroscopy (ICP) must be used. Use an outside service for analytical testing. Review Appendix G for detailed information about testing.

Testing procedures

- To indicate whether the system is working, check the solution *weekly*

See Appendix G for more information about testing for silver.

Testing records

- All test results must be recorded in a silver recovery log. See the examples below. Check with the POTW to find out how long to keep records on file.

Silver Recovery Log		
Date	Weekly Effluent Check*	
	Electrolytic	CRC
7/1/96	P	P
7/8/96	P	P
7/15/96	P	F

* Pass (P) = no color, Fail (F) = color

When the weekly check indicates cartridge failure, refer to the equipment manual for the manufacturer's recommendations.

Silver Recovery Log (ppm)			
Date	Annual Test		% Recovery
	Influent	Effluent	
7/1/96	2350	240	90%
7/1/97			
7/1/98			

To obtain the percent recovery, use the following formula:
 $100 - (\text{effluent} \times 100 \div \text{influent})$.

3. Off-site management

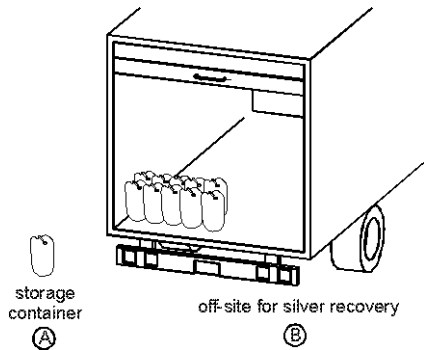

How it works

In this configuration, the silver-rich solution overflow from the processor is stored in a container (A) until it is picked-up by a licensed hauler for off-site silver recovery, treatment and/or disposal (B).

Testing requirements

There are no Code of Management Practice testing requirements for verifying silver recovery efficiencies. State waste agencies, however, may require testing in order to characterize the waste.

Additional requirements

Commercial imaging facilities using off-site management must meet the following requirements:

- Accumulate the silver-rich solutions in a container that's compatible with processing solutions.
- Provide secondary containment for storage tanks or containers, if required in your jurisdiction.

- Comply with all applicable hazardous waste and DOT regulations.
- Keep records of volumes and types of solutions transferred off-site. See the example log below.

Date	Amount (gallons)	Type of Solution	Manifest Number
2/6/96	44	silver - rich photo	MI 3084201
3/5/96	44	silver - rich photo	MI 3084202
4/2/96	55	silver - rich photo	MI 3084203
5/7/96	48	silver - rich photo	MI 3084204
6/4/96	55	silver - rich photo	MI 3084205

- Maintain logs, hazardous waste manifests, land disposal restriction forms and other records for at least five years. Make the records available for inspection by the sewage treatment authorities.
- Verify that the contractor is properly licensed to transport your waste and is handling it correctly.

4.0 Medium Commercial Imaging Facility

A medium commercial imaging facility is one that produces more than 2 but less than 20 gallons per day of silver-rich solutions. Medium facilities must recover silver to at least 95 percent efficiency.

Remember: the category size of medium is based on an individual machine, not the whole facility, unless centralized treatment is used. This is done to ensure the silver recovery equipment and testing recommendations are appropriate for the size and utilization of the processing equipment.

If you are a medium facility, you have five practical options for compliance (achieving a 95 percent removal). These can be configured in several ways, discussed below.

4.1 Compliance Options

The following silver recovery options are recommended for recovering at least 95 percent of the silver from silver-rich solutions:

1. terminal electrolytic unit followed by a chemical recovery cartridge (CRC) with manufacturer specified flow control*, or
2. in-line electrolytic unit with a chemical recovery cartridge (CRC) with manufacturer specified flow control, or

* Flow control may be gravity feed or a metering pump, depending upon the design capabilities of the cartridge and the processing workload. Work with your supplier to determine the flow control appropriate for your system.

3. two or more CRCs with manufacturer specified flow control, or
4. off-site management (including evaporation/distillation), or
5. alternative technology providing at least 95 percent silver recovery.

4.2 Equipment Configurations

In this section for medium commercial imaging facilities, we'll review typical silver recovery equipment configurations for each of the compliance options. Detailed information is available in the appendices.

We'll also describe the testing methods and procedures to use with the equipment to verify that it is recovering at least 95 percent of the silver.

Finally, we'll show you samples of simple silver recovery logs to use for recording the results of the testing.

For detailed information about a specific type of silver recovery equipment, how it works, and preventive maintenance recommendations, refer to:

- Appendix B Electrolytic Silver Recovery
- Appendix C Chemical Recovery Cartridges
- Appendix D Off-Site Management
- Appendix E Evaporation/distillation

1. Terminal electrolytic unit followed by a chemical recovery cartridge (CRC) with manufacturer specified flow control

How it works

In this configuration, the silver-rich overflow from the processor (A) is directed to the electrolytic unit (B). When sufficient silver-rich solution has accumulated, the electrolytic unit begins to desilver the solution. When the batch is completed, the partially desilvered solution is pumped out of the electrolytic unit (C) into the holding tank (D-optional). From here, it is metered (E-optional) at a fixed rate through the chemical recovery cartridge (G). Once the solution exits the cartridge (H) at least 95 percent of the silver has been recovered and the solution can be discharged to the drain (I).

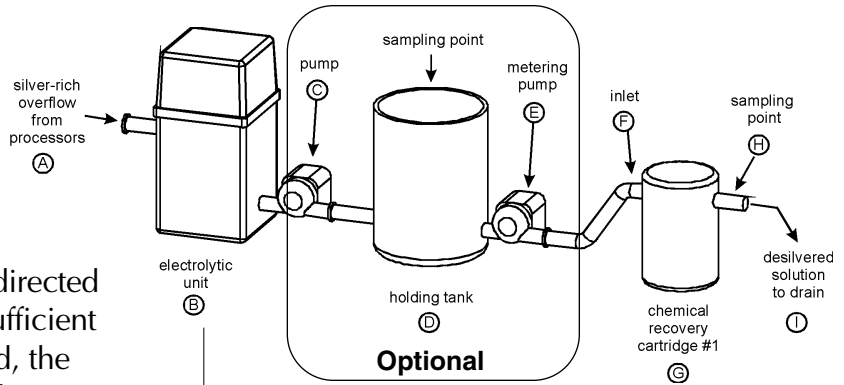

silver estimating test paper at two locations:

- after the electrolytic unit at (D)
- after the CRC at (H)

2. To verify the percent efficiency of the system, use an analytical laboratory to test the solution *once every six months*, from two locations:

- before the electrolytic unit at (A)
- after the CRC at (H)

See Appendix G for more information about testing for silver.

Testing records

- All test results must be recorded in a silver recovery log. See the examples below. Check with the POTW to find out how long to keep records on file.

Testing methods

There are two types of testing methods you must use:

- **once each week**, silver estimating test papers or another method of approximating silver concentration must be used to indicate whether the system is working (if the paper shows any change in color, the system is not working), and
- **once every six months**, highly accurate analytical laboratory testing such as atomic absorption (AA) or inductively coupled plasma spectroscopy (ICP) must be used. Use an outside service for analytical testing.

Testing procedures for silver recovery efficiency

1. To indicate whether the system is working, check the solution *weekly* with

Silver Recovery Log		
Date	Weekly Effluent Check*	
	Electrolytic	CRC
7/11/96	P	P
7/18/96	P	P
7/15/96	P	F

* Pass (P) = no color, Fail (F) = color

When the weekly check indicates cartridge failure, refer to the equipment manual for the manufacturer's recommendations.

Silver Recovery Log (ppm)			
Date	Six Month Test		% Recovery
	Influent	Effluent	
7/5/96	2650	133	95%
1/5/97			
7/1/97			

To obtain the percent recovery, use the following formula:
 $100 - (\text{effluent} \times 100 \div \text{influent})$.

2.. In-line electrolytic unit with a chemical recovery cartridge (CRC) with manufacturer specified flow control

How it works

In this configuration, the silver-rich overflow from the processor (A) is continuously recirculated through the electrolytic silver recovery unit (B) and back into the fixer tank (A). Fixer overflow (C) is fed into the holding tank (D). From here, it is metered (e) at a fixed rate through the chemical recovery cartridge (G). Once the solution exits the cartridge (H) at least 95 percent of the silver has been recovered and the solution can be discharged to the drain (I).

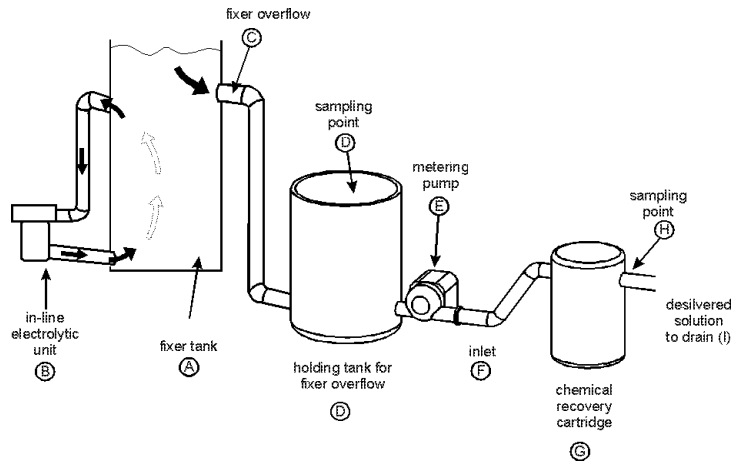

Testing methods for silver recovery efficiency

There are two types of testing methods you must use:

- **once each week**, silver estimating test papers or another method of approximating silver concentration must be used to indicate whether the system is working (if the paper shows any change in color, the system is not working), and
- **once every six months**, highly accurate analytical laboratory testing such as atomic absorption (AA) or inductively coupled plasma spectroscopy (ICP) must be used. Use an outside service for analytical testing. Review Appendix G for detailed information about testing.

Testing procedures

1. To indicate whether the system is working, check the solution *weekly* with silver estimating test papers at two locations:
 - after the electrolytic unit at (D)
 - after the CRC at (H)

2. To verify the percent efficiency of the system, use an analytical laboratory to test the solution *once every six months*, from two locations:
 - before the electrolytic unit at (A) (in the fixer processing tank)[†]
 - after the CRC at (H)

See Appendix G for more information about testing for silver.

Testing records

- All test results must be recorded in a silver recovery log. See the examples below. Check with the POTW to find out how long to keep records on file.

Date	Weekly Effluent Check*	
	Electrolytic	CRC
7/1/96	P	P
7/8/96	P	P
7/15/96	P	F

* Pass (P) = no color, Fail (F) = color

When the weekly check indicates cartridge failure, refer to the equipment manual for the manufacturer's recommendations.

Date	Six Month Test		% Recovery
	Influent	Effluent	
7/5/96	2500	129	95%
1/5/97			
7/1/97			

To obtain the percent recovery, use the following formula:
 $100 - (\text{effluent} \times 100 \div \text{influent})$.

[†] Because no pre-silver recovery measurement is possible, a baseline silver level of 2500 ppm is assumed.

3. Two or more chemical recovery cartridges (CRCs) with manufacturer specified flow control

How it works

In this configuration, the silver-rich overflow from the processor (A) is directed to the holding tank (B). Next, it is metered (C) at a fixed rate through the chemical recovery cartridges (CRCs) set up in series (E and G). In this diagram two CRCs are shown. Once the solution exits the last cartridge in series (H) at least 95 percent of the silver has been recovered and the solution can be discharged to the drain (I).

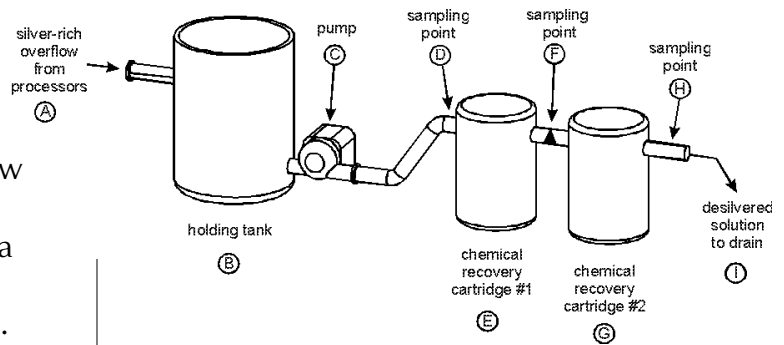

Testing methods for silver recovery efficiency

There are two types of testing methods you must use:

- **once each week**, silver estimating test papers or another method of approximating silver concentration must be used to indicate whether the system is working (if the paper shows any change in color, the system is not working), and
- **once every six months**, highly accurate analytical laboratory testing such as atomic absorption (AA) or inductively coupled plasma spectroscopy (ICP) must be used. Use an outside service for analytical testing. Review Appendix G for detailed information about testing.

Testing procedures

1. To indicate whether the system is working, check the solution *weekly* with silver estimating test papers at two locations:
 - after the first CRC at (F)
 - after the second CRC at (H)

2. To verify the percent efficiency of the system, use an analytical laboratory to test the solution *once every six months*, from two locations:
 - before the first CRC at (B)
 - after the second CRC at (H)

See Appendix G for more information about testing for silver.

Testing records

- All test results must be recorded in a silver recovery log. See the example below. Check with the POTW to find out how long to keep records on file.

Silver Recovery Log		
Date	Weekly Effluent Check*	
	CRC #1	CRC #2
7/1/96	P	P
7/8/96	P	P
7/15/96	F	P

* Pass (P) = no color, Fail (F) = color

When the weekly check indicates cartridge failure, refer to the equipment manual for the manufacturer's recommendations.

Silver Recovery Log (mg/L)			
Date	Six Month Test		% Recovery
	Influent	Effluent	
7/5/96	1784	89	95%
1/5/97			
7/5/98			

To obtain the percent recovery, use the following formula:
 $100 - (\text{effluent} \times 100 \div \text{influent})$.

4. Off-site management

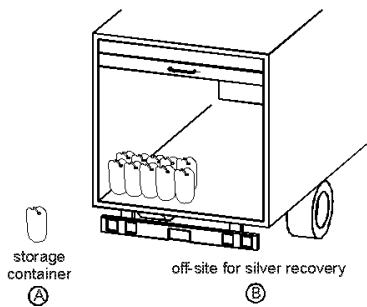

How it works

In this configuration, the silver-rich solution overflow from the processor is stored in a drum (A) until it is picked-up by a licensed hauler for off-site silver recovery, treatment and/or disposal (B). Commercial imaging operations can reduce the volume of waste using evaporation or distillation to reduce hauling charges. This technique does not change the total amount of silver available. (see Appendix E.)

Testing requirements

There are no Code of Management Practice testing requirements for verifying silver recovery efficiencies. State waste agencies, however, may require testing in order to characterize the waste.

Additional requirements

Commercial imaging operation using off-site management must meet the following requirements:

- Store the silver-rich solutions in a container that's compatible with Commercial imaging processing solutions.

- Provide secondary containment for storage tanks and drums, if required in your jurisdiction.
- Comply with all applicable hazardous waste and DOT regulations.
- Keep records of volumes and types of solutions transferred off-site. See the example log below.

Date	Amount (gallons)	Type of Solution	Manifest Number
2/6/96	44	silver - rich photo	MI 3084201
3/5/96	44	silver - rich photo	MI 3084202
4/2/96	55	silver - rich photo	MI 3084203
5/7/96	48	silver - rich photo	MI 3084204
6/4/96	55	silver - rich photo	MI 3084205

- Maintain logs, hazardous waste manifests, land disposal restriction forms and other records for at least five years. Make the records available for inspection by the sewage treatment authorities.
- Verify that the contactor is properly licensed to transport your waste and is handling it correctly.

5.0 Large Commercial Imaging Facility

A large commercial imaging facility is one that produces more than 20 gallons per day of silver-rich solutions. Large operations must recover silver to at least 99 percent efficiency.

Remember: the category size of large is based on an individual machine, not the whole facility, unless centralized recovery is used. This is done to ensure the silver recovery equipment and testing recommendations are appropriate for the size and utilization of the processing equipment.

If you are a large facility, you have four practical options for compliance (achieving a 99 percent removal). These can be configured in several ways, discussed below.

5.1 Compliance Options

The following silver recovery options are recommended for recovering at least 99 percent of the silver from silver-rich solutions. Ion exchange may be used in combination with other compliance options to achieve 99 percent recovery with the wastewater from the processors:

1. terminal electrolytic unit followed by two chemical recovery cartridge (CRC) with manufacturer specified flow control, or

2. in-line electrolytic unit with two chemical recovery cartridge (CRC) with manufacturer specified flow control, or
3. off-site management (including evaporation/distillation), or
4. alternative technology providing at least 99 percent silver recovery.*

5.2 Equipment Configurations

In this section for large facilities, we'll review typical silver recovery equipment configurations for each of the compliance options. Detailed information is available in the appendices.

We'll also describe the testing methods and procedures to use with the equipment to verify that it is recovering at least 99 percent of the silver.

Finally, we'll show you samples of simple silver recovery logs to use for recording the results of the testing.

For detailed information about a specific type of silver recovery equipment, how it works, and preventive maintenance recommendations, refer to:

Appendix B Electrolytic Silver Recovery
 Appendix C Chemical Recovery Cartridges
 Appendix D Off-Site Management
 Appendix E Evaporation & Distillation
 Appendix F Ion Exchange

* This option allows for improvements to existing technology and for new technology developed after this guide was written. It also allows for less commonly used technology that is available and can meet the percent recovery requirements.

1. Terminal electrolytic unit followed by two or more chemical recovery cartridges (CRC) with manufacturer specified flow control

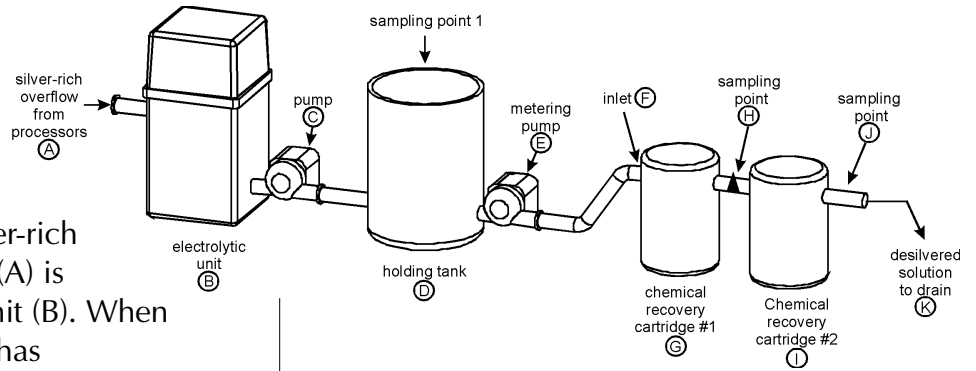

How it works

In this configuration, the silver-rich overflow from the processor (A) is directed to the electrolytic unit (B). When sufficient silver-rich solution has accumulated, the electrolytic unit begins to desilver the solution. When the batch is completed, the partially desilvered solution is pumped out of the electrolytic unit (C) into the holding tank (D). From here, it is metered (E) at a fixed rate through the CRCs (G, I). Once the solution exits the last CRC (I) at least 99 percent of the silver has been recovered and the solution can be discharged to the drain (K).

Testing methods for silver recovery efficiency

There are two types of testing methods you must use:

- **once each week**, silver estimating test papers or another method of approximating silver concentration must be used to indicate whether the system is working (if the paper shows any change in color, the system is not working), and
- **once every three months**, highly accurate analytical laboratory testing such as atomic absorption (AA) or inductively coupled plasma spectroscopy (ICP) must be used. Use an outside service for analytical testing. Review Appendix G for detailed information about testing.

Testing procedures

1. To indicate whether the system is working, check the solution **weekly**

with silver estimating test papers at three locations:

- after the electrolytic unit at (D)
- after the first CRC at (H)
- after the last CRC at (J)

2. To verify the percent efficiency of the system, use an analytical laboratory to test the solution *once every three months*, from two locations:

- before the electrolytic unit at (A)
- after the last CRC at (J)

See Appendix G for more information about testing for silver

Testing records

- All test results must be recorded in a silver recovery log. See the example below. Check with the POTW to find out how long to keep records on file.

Silver Recovery Log			
Date	Weekly Effluent Check*		
	Electrolytic	CRC #1	CRC #2
7/1/96	P	P	P
7/8/96	P	P	P
7/15/96	P	F	P

* Pass (P) = no color, Fail (F) = color

When the weekly check indicates cartridge failure, refer to the equipment manual for the manufacturer's recommendations.

Silver Recovery Log (mg/L)			
Date	Three Month Test		% Recovery
	Influent	Effluent	
7/5/96	1876	17	99%
10/5/96	2016	18	99%
1/5/97			

To obtain the percent recovery, use the following formula:
 $100 - (\text{effluent} \times 100 \div \text{influent})$

2.. In-line electrolytic unit with a chemical recovery cartridge (CRC) with manufacturer specified flow control

How it works

In this configuration, the silver-rich overflow from the processor (A) is continuously recirculated through the electrolytic silver recovery unit (B) and back into the fixer tank (A). Fixer overflow (C) is fed into the holding tank (D). From here, it is metered (E) at a fixed rate through the chemical recovery cartridges (E). Once the solution exits the cartridge (H) at least 99 percent of the silver has been recovered and the solution can be discharged to the drain (I).

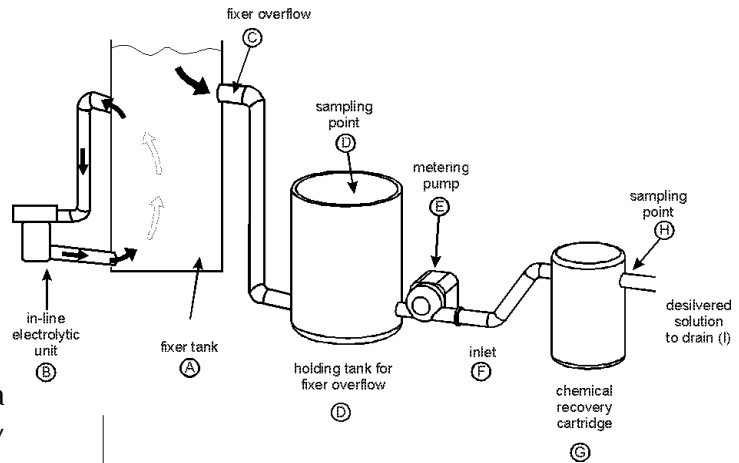

Testing methods for silver recovery efficiency

There are two types of testing methods you must use:

- **once each week**, silver estimating test papers or another method of approximating silver concentration must be used to indicate whether the system is working (if the paper shows any change in color, the system is not working), and
- **once every three months**, highly accurate analytical laboratory testing such as atomic absorption (AA) or inductively coupled plasma spectroscopy (ICP) must be used. Use an outside service for analytical testing.

Testing procedures

1. To indicate whether the system is working, check the solution *weekly* with silver estimating test papers at three locations:
 - after the electrolytic unit at (D)
 - after the first CRC at (F)
 - after the second CRC at (H)

2. To verify the percent efficiency of the system, use an analytical laboratory to test the solution *once every three months*, from two locations:
 - before the electrolytic unit at (A) (in the fixer processing tank)*
 - after the last CRC at (H)

See Appendix G for more information about testing for silver.

Testing records

- All test results must be recorded in a silver recovery log. See the examples below. Check with the POTW to find out how long to keep records on file.

Silver Recovery Log		
Date	Weekly Effluent Check*	
	Electrolytic	CRC
7/1/96	P	P
7/8/96	P	P
7/15/96	P	F

* Pass (P) = no color, Fail (F) = color

When the weekly check indicates cartridge failure, refer to the equipment manual for the manufacturer's recommendations.

Silver Recovery Log (ppm)			
Date	Three Month Test		% Recovery
	Influent	Effluent	
7/5/96	2500	129	95%
1/5/97			
7/1/97			

To obtain the percent recovery, use the following formula:
 $100 - (\text{effluent} \times 100 \div \text{influent})$.

† Because no pre-silver recovery measurement is possible, a baseline silver level of 2500 ppm is assumed.

4. Off-site management

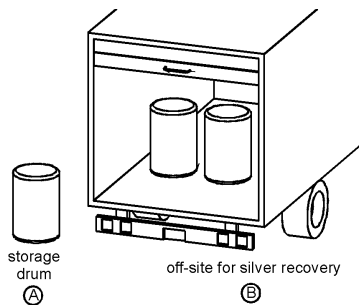

How it works

In this configuration, the silver-rich solution overflow from the processor is stored in a drum (A) until it is picked-up by a licensed hauler for off-site silver recovery, treatment and/or disposal (B). Commercial imaging operations can reduce the volume of waste using evaporation or distillation to reduce hauling charges. This technique does not change the total amount of silver available. (see Appendix E.)

Testing requirements

There are no Code of Management Practice testing requirements for verifying silver recovery efficiencies. State waste agencies, however, may require testing in order to characterize the waste.

Additional requirements

Commercial imaging processing operations using off-site management must meet the following requirements:

- Accumulate the silver-rich solutions in a drum that's compatible with commercial imaging processing solutions.

- Provide secondary containment for storage drums, if required in your jurisdiction.
- Comply with all applicable hazardous waste and DOT regulations.
- Keep records of volumes and types of solutions transferred off-site. See the example log below.

Date	Amount (gallons)	Type of Solution	Manifest Number
2/6/96	44	silver - rich photo	MI 3084201
3/5/96	44	silver - rich photo	MI 3084202
4/2/96	55	silver - rich photo	MI 3084203
5/7/96	48	silver - rich photo	MI 3084204
6/4/96	55	silver - rich photo	MI 3084205

- Maintain logs, hazardous waste manifests, land disposal restrictions forms and other records for at least five years. Make the records available for inspection by the sewage treatment authorities.
- Verify that the contractor is properly licensed to transport your waste and is handling it correctly.

6.0 Pollution Prevention

This section of the guide introduces several voluntary activities that can result in preventing pollution. We recommend that you read through it and adopt any ideas that are appropriate to your processing operation. While many of these activities are better suited to larger operations, there are some that can also benefit even the smallest film processor

Your industry has a long history of practicing waste minimization or waste control, whether it's through the use of photo processing solutions with reduced replenishment rates or reduction of silver in films. Using good waste control practices has two benefits: it can lower the impact our businesses have on the environment and it can save money through reduced material consumption and labor.

In today's language, waste control is called *pollution prevention*. Pollution prevention, or *P2*, is the name given to good management practices, as well as equipment and chemical modifications that result in reducing or eliminating waste—before it's generated.

Most commercial imaging facilities are already using some pollution prevention practices. In this section of the *Commercial Imaging Guide to the Code of Management Practice* we're going to give you a method to look at your imaging operation, identify options for pollution prevention, put a voluntary P2 plan in place and follow-up on the success of that plan. The diagram on the next page shows the five steps of P2 planning:

1. Put a team together of interested and capable staff and management employees to develop and oversee pollution prevention activities in your facility.

2. Identify and review your options by examining your current practices in light of alternative or additional measures that can reduce or eliminate waste.

3. Develop a P2 plan by deciding which options you'll adopt, the time frame for adopting them, and who will be responsible for overseeing the option is implemented and maintained.

4. Put the plan in place by providing the staff with pollution prevention training and resources. Do not underestimate the importance of the human factor.

5. Track your results and provide feedback by keeping records where they are helpful and by routinely auditing or inspecting your imaging operation for pollution prevention.

Not every pollution prevention activity discussed in this section will make sense for your facility. For example, if the processing volume is low, an in-line silver recovery system may not be a good choice. This is just one example of why it's so important for you to conduct a thorough review of your facility and examine your options before you begin to develop a P2 plan.

Planning for Pollution Prevention

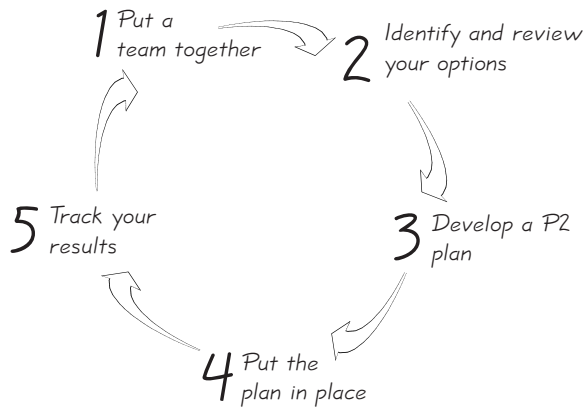

In the following pages of this section, we provide you with specific P2 information and checklists to assess your performance.

6.1 Put a Team Together

Commitment from management and staff is an essential element of a successful pollution prevention plan.

Management shows its support by 1) developing, implementing and maintaining a P2 policy, 2) forming a P2 team and 3) by allowing adequate time and resources for P2 activities.

Staff shows its support by working with management to ensure pollution prevention is a priority.

a. Management activities

There's no substitution for good leadership in pollution prevention. Management has a key role to play by setting direction, eliminating barriers to change and motivating employees.

A pollution prevention policy

A pollution prevention policy is a simple and clear statement that waste reduction and elimination are important goals of your company. The policy can be developed with the help of the P2 team (discussed next). We've provided an example of a policy. Make sure it's signed by the president, owner or plant manager to show commitment and responsibility to P2 activities.

Once the policy is developed, it should be posted for all employees, and customers, to see.

Remember—the success of P2 depends upon support from all the people in the company.

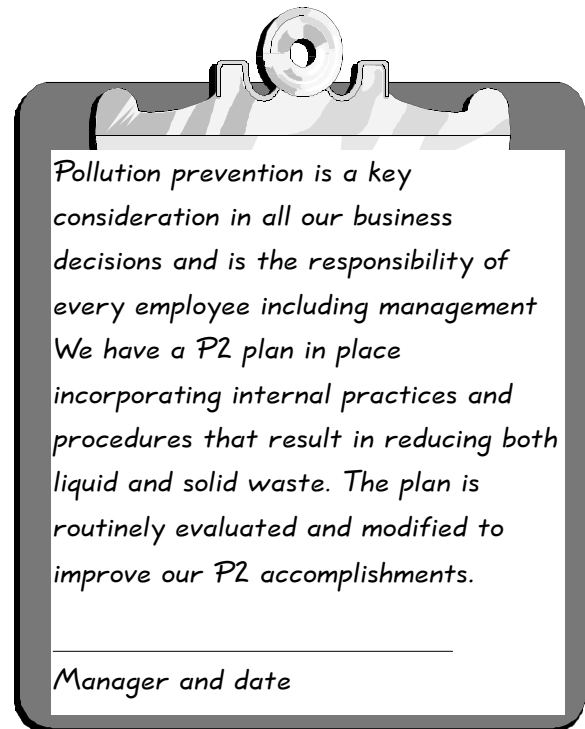

The P2 team

The pollution prevention team is the group of managers and staff people who develop, implement and evaluate all the activities that go into making up the P2 plan.

- *How many people should be on the team?* That depends upon the size of your operation. In a three or four person printing company, it might be a team of one—the manager. In a large company, it might be a team of five or six. You decide how many people you need.

- *Who makes the best team member?* The best team member is someone who's interested in pollution prevention, wants to be on the team and has a good understanding of the entire Commercial imaging system. In large companies, try to get representatives of different departments

- *What about a team leader?* The P2 team needs a leader. Management can leave that decision up to the team or it can designate someone.

Time and resources for the P2 team

The P2 team needs time and resources to do its job properly. Time means time to meet, audit the facility, develop the P2 plan, implement it and periodically evaluate it. Resources means training and technical information such as equipment operation, maintenance procedures, film volume and replenishment rates. Management must provide these as part of its commitment to P2.

b. Staff activities

Everyone has a part to play in pollution prevention. Some staff will be part of the P2 team. Their responsibilities will include participation in the development and implementation of the plan.

The rest of the staff will be trained to recognize pollution prevention opportunities and to work in such a way that doesn't create waste in the first place.

Checklist

This checklist reviews all the elements for putting together a P2 team. When you have the team in place, you should be able to answer "Yes" to all questions. "No" answers are potential pollution prevention opportunities. When you don't have adequate information to answer, mark the "?" Then get the information you need to make an assessment.

<i>Pollution Prevention Team</i>			
	Yes	No	?
• Do you have a company P2 policy?			
• Has it been signed and dated by management?			
• Is the policy posted where all employees can see it?			
• Is the policy posted where all customers can see it?			
• Have employees been told about the P2 policy and its purpose?			
• Has the P2 team been formed?			
• Are the team members knowledgeable about film processing?			
• Has a team leader been chosen?			
• Does management provide the team with the time and resources needed for P2 planning and implementation?			

6.2 Review Your Options

Pollution prevention options for processing solutions can be broken into three categories:

- 1) management practices,
- 2) equipment modifications, and
- 3) process modifications.

Each of these will be examined here. We'll also look at options for managing the solid waste produced in a Commercial imaging operation.

At this phase of the P2 process, we're only *looking* at the available options. After each discussion, we've included a checklist for you to evaluate your practices and equipment. A "Yes" answer means you're already practicing that P2 activity. Anytime you answer "No" you've found a potential pollution prevention opportunity. Anytime you answer "?" it means you need more information to evaluate the option. When you finish, look back at the checklists and with the team, choose the best P2 options for your company.

a. Management practices

Some of the easiest and least expensive management practices produce the most effective pollution prevention results. Keep this in mind as we look at the following management practices.

Preventive maintenance

Preventive maintenance should be your first pollution prevention option. By implementing a complete preventive maintenance program, the equipment will work at its optimum level, keeping waste at a minimum. Use the recommendations found in the equipment operating manual

as a starting point for your preventive maintenance program.

Process control

Process control is the routine monitoring of variables that affect the quality of your product. These variables include:

- replenishment rates,
- processing temperatures,
- processing time, and
- chemical mix procedures.

They should be checked on a periodic basis to ensure that the film image quality is good and waste is minimized. These variables should be monitored on a set schedule tied to the preventive maintenance schedule.

Commercial imaging operations **should** also routinely run control strips, chart the results of each strip (as shown on the chart below) and take action based on the results.

Example process control chart

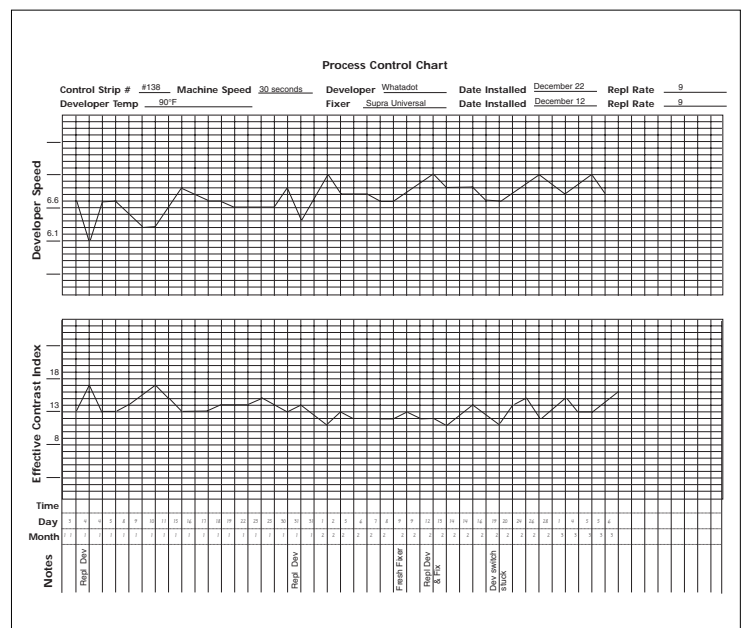

Inventory control

Managing the chemical inventory includes rotating the stock so that the oldest is used first and maintaining an appropriate supply of chemicals on-hand. This reduces the risk of having old chemicals in inventory and reduces the amount of money tied-up in overstock.

Spill response planning

Any time a solution is unintentionally released it's a spill. The key word is *unintentional*. When you produce a waste solution during rack washing, it's intentional. But if a container of photographic processing solution is dropped on the floor, ruptures and leaks, you have an unintentional spill.

Most spills are minor splashes or leaks and can be cleaned up with a sponge or mop. Occasionally, however, a larger spill could occur requiring specialized clean-up materials and procedures.

The time to plan for a spill is long before it happens. A good spill response plan will help minimize the effects of the spill on the environment and ensure the Commercial imaging facility returns to normal as quickly as possible. Some of the things to include in your spill response plan include:

- an inventory of all the chemicals used in the commercial imaging operation;
- a floor plan showing the location of all chemicals in the processing area, floor drains, exits, fire extinguishers and spill response supplies;

- a description of the containment used for silver recovery cartridges, mixing tanks, chemical storage tanks and any other containers that could leak or rupture;
- a list of spill response supplies and equipment such as mop, pail, sponge, co-polymer or other absorbent materials, neutralizing materials and personal protective equipment; and
- a set of tested procedures for responding to a spill. A sample spill response procedure, as shown below is included in Appendix H.

Mr. Opaque Pre-Press Ltd.	
SPILL CONTINGENCY PLAN	
Spill Response Personnel	
<i>Don Spillit</i>	999-5555
Name	pager/phone
<i>Ruth Typeset</i>	555-9999
Name	pager/phone
<i>Bill Sorbit</i>	898-5656
Name	pager/phone
Environmental Emergency Phone	(999) 999-9999 24 hours a day 7 days a week
EQUIPMENT REQUIRED	
<ul style="list-style-type: none"> • Gloves • Apron • Goggles 	<ul style="list-style-type: none"> • Bucket • Mop • Sponge
<ul style="list-style-type: none"> • Absorbent Materials • Neutralizing Materials 	
SPILL RESPONSE PROCEDURES	
<ol style="list-style-type: none"> 1. Put on gloves, goggles and an apron. 2. Contain the spill with a mop or absorbent materials available. 3. Check the appropriate material safety data sheet (MSDS) for special handling, ventilation, personal protection or other pertinent data. 4. Clean up the spill, as directed, using generous amounts of water. 5. Use the mop and sponge to clean the area thoroughly. 6. Package and label all contaminated absorbent materials for off-site disposal. 7. Notify the supervisor or manager that a spill has occurred. 8. (If required) Notify appropriate government agency that a spill has occurred. 	

Good housekeeping

In a clean and orderly operation, there's better control over materials and equipment and less likelihood of spills. This results in less operational waste and prevents pollution.

Good housekeeping is one of those inexpensive and simple management practices that can significantly reduce waste, increase productivity and lower costs. You can't afford to neglect it.

Here are three basic good housekeeping guidelines:

1. Designate an appropriate storage area for all materials and equipment.
2. Require every employee to return all materials and equipment to their designated area.
3. Establish a procedure and a schedule to inspect chemical receiving, storage, mixing and use areas for spills, leaks, cleanliness and orderliness.

Safety and security

Keeping chemical areas safe and secure can minimize spills and other upsets.

- Make sure there is always someone trained in spill response procedures in the facility or who can be contacted to respond immediately.
- Restrict staff admittance to areas where chemicals are used and stored to staff who have had hazard communication training.
- Make sure there's an MSDS on file for every chemical in the facility.
- Maintain a security system so that you know when someone is in the facility, both during and after working hours.

Checklist

This checklist reviews all the elements for evaluating management practices. "Yes" answers indicate that you're already using that pollution prevention measure. "No" answers are potential pollution prevention opportunities. When you don't have adequate information to answer, mark the "?" Then get the information you need to make an assessment.

<i>Management Practices</i>			
<i>Preventive Maintenance</i>	Yes	No	?
<ul style="list-style-type: none"> Is there a preventive maintenance program in place incorporating all the equipment manufacturer recommendations? 			
<i>Process Control</i>	Yes	No	?
<ul style="list-style-type: none"> Are solution replenishment rates routinely monitored? Are processing tank temperatures routinely checked? Are processing times routinely checked? Are standard chemical mix procedures used by all staff? Are control strips run on processors at least once per shift? Are all control strips plotted on control charts? When corrective action is taken, is it noted on the control chart? 			
<i>Inventory Control</i>	Yes	No	?
<ul style="list-style-type: none"> Is the oldest chemical stock always used first? Are appropriate levels of stock maintained? 			
<i>Spill Response Planning</i>	Yes	No	?
<ul style="list-style-type: none"> Is there a spill response plan? Is it posted in the chemical mix area? Is an inventory of all chemicals posted in the imaging area? Is there a floor plan detailing the location of chemicals, floor drains, exits, fire extinguishers and spill response supplies? Is there containment around all permanent chemical containers? Are the spill response supplies easily accessible? Are spill response personnel properly trained? 			

<i>Management Practices (continued)</i>			
<i>Good housekeeping</i>	Yes	No	?
• Are all materials and equipment kept in a specified location?			
• Are all chemical containers routinely checked for cracks or leaks?			
• Is all equipment wiped clean of chemical residue and dirt?			
• Are all floors free of chemical spills and residue?			
• Are aisles and walkways clear?			
• Does the Commercial imaging area look orderly and clean?			
• Are all employees held accountable for good housekeeping?			
<i>Safety and Security</i>	Yes	No	?
• Is there at least one staff member trained in spill response in the facility at all times?			
• Are areas where chemicals are used and stored restricted to staff trained in safe chemical handling?			
• Is there an MSDS for every chemical in the facility?			
• Is there a security system in place during working and nonworking hours?			

b. Equipment modifications

A second category of pollution prevention options is equipment modifications. This refers to the changes made to film and paper processors to reduce the amount of waste solution produced through processing. As we examine each of these options remember what we said earlier:

Not every one of these options is appropriate for your equipment. In some cases, equipment cannot be modified or is not an economical option. Check with your equipment manufacturer.

Squeegee Rollers

Squeegee rollers are an effective P2 option that improves silver recovery. As the film exits the fix tank, it carries over a certain amount of silver-rich solution into the wash. Squeegee rollers reduce carryover, therefore keeping the silver in the fix tank where the overflow can be sent to silver recovery instead of being lost in the wash tanks.* Care and routine maintenance can extend the life and effectiveness of squeegee rollers.

In-line silver recovery

Another way to reduce the silver carried over from the fix tank into the wash tanks is to reduce the concentration of silver in the fix. This can be done with in-line silver recovery.

In-line silver recovery is an electrolytic unit through which the fix in the processor tank is recirculated and constantly desilvered. Because the silver concentration is kept at a low, fixed amount, this significantly reduces the concentration of silver carried over into the wash.

* Squeegee rollers are also used between the developer and fixer tanks. This minimizes developer carryover that contaminate the fixer.

There are other benefits of in-line silver recovery. Generally, it's possible to use a lower fix replenishment rate which means lower fixer consumption. Additionally, the silver recovered is high grade silver flake.

If you use in-line silver recovery, check with your chemical supplier to determine if you need a specially formulated fixer.

Stand-by Wash

Today, most processors come equipped with an extremely efficient water saving device called stand-by wash. This controls the wash water so it runs *only* when the film is being processed. When the film clears the machine, the wash goes into standby position and doesn't begin again until the next film is processed. This equipment modification can save hundreds of gallons of water. If you have an older machine, check with your supplier to find out if it is possible to have it modified for a standby wash.

Checklist

This checklist reviews all the elements for evaluating equipment modifications. "Yes" answers indicate that you're already using that pollution prevention measure. "No" answers are potential pollution prevention opportunities. When you don't have adequate information to answer, mark the "?" Then get the information you need to make an assessment.

<i>Equipment modifications</i>			
<i>Squeegee Rollers</i>	Yes	No	?
• Are there squeegee rollers on processors capable of being equipped?			
• Are all squeegee rollers routinely checked and replaced?			
• Are all squeegee rollers cleaned as part of the shut-down procedure?			
<i>In-line Silver Recovery</i>	Yes	No	?
• Is there an in-line electrolytic unit on all film fixer tanks?			
• Is the silver concentration in the tank monitored so that it doesn't get below 500 ppm or above 1000 ppm?			
• Is the fixer appropriate for in-line silver recovery?			
• Has the fixer replenishment rate been reduced?			
<i>Standby Wash (if applicable)</i>	Yes	No	?
• Are the processors equipped with standby wash?			

c. Process modifications

The third category of pollution prevention options is process modifications. Just as with equipment modifications, not all processors can be changed to accommodate every one of these process modifications.

Solution regeneration and reuse

Regenerating and reusing fixer may reduce the amount of chemicals to be desilvered or discharged to the drain. If the equipment can be modified and the film use is high enough, this pollution prevention option can significantly reduce waste. **Talk with your film and chemical suppliers to find out if this option is appropriate for your facility.**

Off-site chemical recycling may also be an option. In this case, the film processing facility collects the fixer overflow at the processor and periodically ships the collected solution to the recycler. From here, the fixer is desilvered and also regenerated for reuse. The regenerated fixer is then returned to the film processing facility to be used as fresh chemical.

Water reuse and recycling

Reducing the amount of water used in processing reduces waste and conserves a valuable resource. Optional process modifications for water conservation include:

- wash water recycling equipment
- manufacturer kits such as metered wash water replenishment and wash water timers.

Because wash water has a direct affect on image stability, always consult with your film manufacturer before making water conservation modifications to the processors.

Dry chemicals and automated mixing

Under some conditions, dry chemical packaging and automated mixing can contribute to waste minimization through extended shelf life and less packaging material.

Checklist

This checklist reviews all the elements for evaluating process modifications. "Yes" answers indicate that you're already using that pollution prevention measure. "No" answers are potential pollution prevention opportunities. When you don't have adequate information to answer, mark the "?" Then get the information you need to make an assessment.

<i>Process modifications</i>			
<i>Replenishment</i>	Yes	No	?
<ul style="list-style-type: none"> • Have replenishment rates been measured or adjusted to manufacturer specifications 			
<i>Solution Reuse</i>	Yes	No	?
<ul style="list-style-type: none"> • Are chemicals regenerated where it's practical? 			
<ul style="list-style-type: none"> • Is the portion of the silver-rich chemicals that is not regenerated sent for silver recovery? 			
<ul style="list-style-type: none"> • Are chemicals reused where it's practical? 			
<i>Water Reuse and Recycling</i>	Yes	No	?
<ul style="list-style-type: none"> • Are wash water rates set at manufacturer recommendations? 			
<ul style="list-style-type: none"> • Does the wash water run only during processing? 			
<ul style="list-style-type: none"> • Is wash water conservation being used? (e.g., metered wash water replenishment or wash water timer) 			
<i>Other Process Modifications</i>	Yes	No	?
<ul style="list-style-type: none"> • Are dry chemicals used where it's practical? 			
<ul style="list-style-type: none"> • Are automated mixers used where it's practical? 			

d. Solid waste

There are pollution prevention opportunities for reducing the solid waste produced in Commercial imaging. For example, film can be sent out for processing and silver removal. Some manufacturers will recycle plastic end caps and chemical cubitainers.

Some cities have recycling programs for corrugated cardboard, office paper and other materials. Reusing and recycling reduces the amount of solid waste going to landfill and lowers your waste disposal fees.

The example below is from a pre-press facility. Use it as a guideline in developing a pollution prevention guide for your operation.

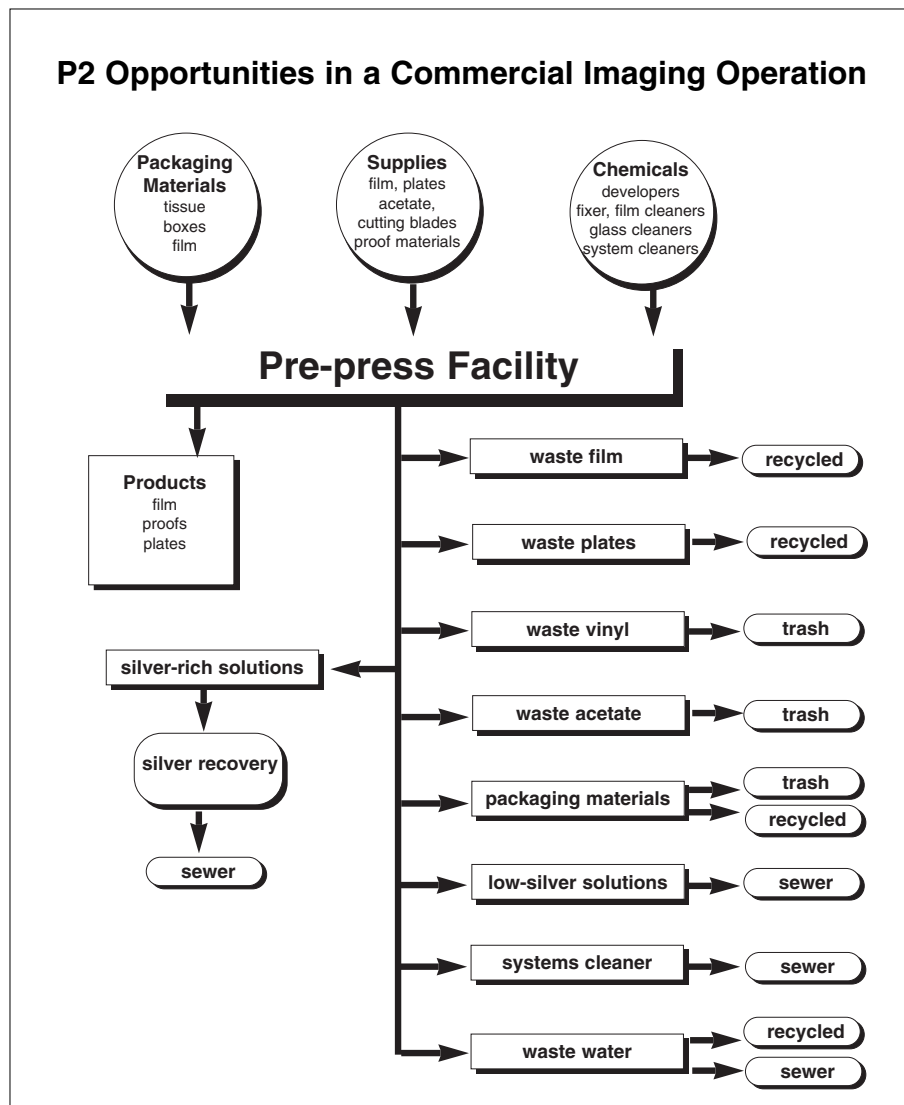

Checklist

This checklist reviews all the elements for evaluating your solid waste management program. "Yes" answers indicate that you're already using that pollution prevention measure. "No" answers are potential pollution prevention opportunities. When you don't have adequate information to answer, mark the "?" Then get the information you need to make an assessment.

<i>Solid Waste</i>			
<i>Are the following solid wastes reused:</i>	Yes	No	?
• Plastic core protectors?			
• Paper cores (cardboard)?			
• Photographic paper bags?			
• Processing equipment filters?			
• Packing materials including pallets and plastic wrap?			
<i>Are the following solid wastes recycled:</i>	Yes	No	?
• Films and plates?			
• Chemical containers or cubitainers?			
• Unwanted or excess exposed and processed film			
• Paper cores (cardboard)?			
• Office paper?			
• Corrugated cardboard?			
• Box board?			
• Packing materials including pallets and plastic wrap?			

6.3 Develop a P2 Plan

Now that the P2 team has finished the audit or review, it's time for them to look at all the options and prioritize them as:

- **High priority**—needs immediate action
- **Medium priority**—needs action within 3 to 12 months
- **Low priority**—needs consideration within the next 1 to 2 years

Screening your options

Screen each option by asking the following questions and writing out your answers:

1. What is the potential for reducing waste and providing other environmental benefits?
2. What is it going to cost in time, materials and equipment costs?
3. How much money will it save in time and materials?
4. How difficult is it to implement?

To show you how this works, look at the following example of screening the option of using in-line silver recovery on the film processor. A blank worksheet is included in Appendix H. Make copies as you need them and leave the original in this Guide.

Example Worksheet for Screening Options

Date 1/17/97

Option: *Installing and maintaining an in-line silver recovery unit on the processor*

1. What is the potential for reducing waste and providing other environmental benefits?

Less silver will be lost to the wash tank and therefore the drain. In addition, we may be able to reduce replenishment rates.

2. What is it going to cost in time and materials?

Cost of the electrolytic unit, labor for installation and periodic replacement, and labor for maintenance. (Estimate actual costs as closely as possible.)

3. How much money will it save in time and materials?

The savings will come in the increased amount of silver recovered (estimate actual savings as closely as possible) and lower fix replenishment rates.

4. How difficult is it to implement?

Not difficult, We can schedule the installment during the next preventive maintenance check on the machine. We need to buy the electrolytic unit. We also need to train process operators to keep the silver concentration about 500 ppm to reduce the potential for sulfiding.

Screening all the options you've identified will take time but it's time well spent. It's very important that you actually write out your answers. Doing your homework here makes the difference between a P2 plan that exists only in your head vs. one that is implemented and working.

Point system

You might find it useful to develop a point system for rating all the options. For example, you could assign a *plus* value to every potential benefit and a *minus* value to every negative impact.

Writing the P2 plan

Whatever system you use, you need to get to the point where you've prioritized all of the options. Now you can begin to draft the P2 plan. For your first attempt at systematic pollution prevention, we recommend that you start with only the **high priority** options. Work at getting

these into place and evaluate your success before addressing the medium and low priority options. Don't make too many changes as once—start with only 1 or 2 items.

Keep your P2 plan simple. Here is the information you should include:

- **Spell out each option and its purpose**
- **State a specific date when the option will be implemented**
- **List who is responsible**
- **Note if a record will be kept**

Review the example below. A blank Pollution Prevention Plan Worksheet is included in Appendix H. Make copies as you need them and leave the original in this Guide.

Example Pollution Prevention Plan Worksheet

Date 2/08/97

Option or activity: *We're going to install the in-line unit on the film processor in order to reduce the amount of silver in the wash water.*

Implementation date: *The unit will be installed during the December preventive maintenance check.*

Responsibility: *Joe Smith, maintenance supervisor, will spec the unit, arrange for purchase, develop an installation plan, ensure it is installed and be responsible for seeing it is maintained. He will also train the process operators how to maintain and harvest the silver.*

Record: *In-Line electrolytic maintenance will be added to the preventive maintenance checklist.*

6.4 Put the Plan in Place

Now that you have a P2 plan it's time to put it into action. These are the steps:

1. Make the plan known - Post it, explain its purpose and details to the employees, and talk it up. Through both your words and actions, make all employees aware of how committed management is to pollution prevention. Keep employees updated on both the successes and failures of the plan.
2. Provide training and education - Make sure that anyone who is given responsibility in the P2 plan has the training and knowledge to carry out his/her tasks.
3. Provide the necessary resources - Make sure that anyone who is given responsibility in the P2 plan has the time and materials required to fully implement the P2 plan.

6.5 Track Your Results

Your P2 plan isn't a "Now I've done it so I can forget about it" kind of thing. You

need to periodically review it, evaluate which elements are working, which need to be modified and which need to be discontinued. A review every six months should be often enough.

As you evaluate your P2 plan, keep in mind your original intent for pollution prevention: minimizing or eliminating waste for both environmental and economic benefit.

Answer each of the following questions for each pollution prevention option or activity listed in your plan:

- **How much waste has been reduced or eliminated as a result of this activity?**
- **How much has it cost?**
- **How much money has it saved?**

In some cases, it may be hard to get exact answers to these questions. But try. It's important that you fully evaluate every P2 option implemented in your commercial imaging operation. Once again, let's look at installing an in-line unit as an example.

Example Worksheet for Evaluating P2

Date 4/20/97

Option: Installing and maintaining in-line electrolytic silver recovery unit on the film processor

1. Waste reduction results

After analyzing the wash water, we found the concentration of silver went from 95 ppm to 12 ppm. Over the 6 month period, we estimate this represents 386 troy ounces of silver.

2. Costs

Materials - unit = \$1240. Labor - installation 1 1/2 hours x \$20/hour = \$30. Daily maintenance - 1 minute at \$12/hour = \$.20 daily or \$24 for 6 months. Total costs = \$1294

3. Savings

386 tr. oz. of silver at \$5.40 tr. oz. = \$2084. This was the amount of silver diverted from the wash.

A *successful* P2 option or activity is one that reduces waste and saves more money than it costs. Consider whether changing it would make it even more successful or whether to let it continue as is.

An *unsuccessful* option or activity is one that doesn't reduce waste, or it costs more money than it saves. With an unsuccessful option, consider whether changing it would make it successful or whether to discontinue using it.

Once you've done this evaluation for every option, you can also consider whether it's time to put some of those **medium priority** options in place. Remember not to make too many changes at once.

Spread the word

Every time you evaluate the success of the P2 plan, let the staff know the results—both the positive and the not so positive. When you decide to make changes or implement new P2 activities, remember to train the staff if there are any new procedures.

Include your P2 success stories in your facility's annual report or newsletter. If there's no environmental section in the report, now is a good time to start one.

With pollution prevention, everyone's a winner: the impact of your business on the environment is reduced and the cost savings from lower waste means more money in your pocket.

P2

Appendix A

Glossary of Terms

AMSA: The Association of Metropolitan Sewerage Agencies represents the interests of the country's largest wastewater treatment agencies. AMSA maintains a key role in the development of environmental legislation and implementation of environmental rules, guidance and policy.

Anode: The positively charged electrode. When electrolytically desilvering commercial imaging processing solutions, the thiosulfate is oxidized at the anode.

Batch Process: The collection of silver-rich solution into a tank or container which is processed through a silver recovery or management system.

Biocide: A chemical that discourages the growth of bacteria.

Cathode: The negatively charged electrode. When electrolytically desilvering commercial imaging processing solutions, metallic silver is deposited on the cathode.

Commercial Imaging Facility: A facility processing pre-press film, micrographics or any other nondiagnostic black and white photographic process.

Code of Management Practice (CMP): The site-specific plan implemented by the individual processing facility for the purpose of controlling and reducing discharges of silver to the POTW.

Continuous Process: The processing of silver-rich solution in a continuous flow from the processing machine through a silver recovery or management system.

Cradle-to-Grave: A phrase used to describe the tracking system for hazardous waste. All parties in the waste chain—generator, transporter, storage and disposal facilities—use a common manifest that identifies them, the waste, and the final disposition of the waste.

CRC: A chemical recovery cartridge which recovers silver through a process known as metallic replacement.

Distillate: The liquid recovered by condensation during the process of distilling or concentrating used processing solutions and wash waters.

DOT: Department of Transportation

Effluent: The solution exiting a process or piece of equipment.

Electrolytic Silver Recovery: A method of recovering silver in which a direct current is applied across two electrodes immersed in a silver-rich solution. Silver plates onto the cathode and the thiosulfate is oxidized at the anode.

Good Housekeeping: Maintenance of a neat, orderly and clean working environment.

Influent: The solution entering a process or piece of equipment.

Ion Exchange: A reversible exchange of ions between a solid (resin) and a liquid (water containing ionized salts). When used with photo processing solutions, ion exchange removes silver and replaces it with ionized salts.

Large Commercial Imaging Facility: A facility which produces on average more than 20 gallons per day (GPD) of silver-rich solution.

Low-Silver Solution: A solution containing insufficient silver for cost effective silver recovery. Low-silver solutions include used developers, stop baths and wash waters.

Manufacturer Specified Flow Control: means a pump or restricted orifice required by the manufacturer to meet and maintain the silver recovery efficiency for metallic replacement cartridges.

Medium Commercial Imaging Facility: A facility which produces on average more than 2 but less than 20 gallons per day (GPD) of silver-rich solution and uses less than 10,000 GPD of process wash water.

Metallic Replacement: A method of recovering silver from silver-rich solutions by an oxidation-reduction reaction with elemental iron and silver thiosulfate to produce ferrous iron and metallic silver. The device used is commonly called a chemical recovery cartridge (CRC).

Milligrams per Liter (mg/L): mg/L is the same measurement as parts per million (ppm).

Off-Site Silver Recovery and Management: Removal of silver-rich solutions from a facility by a hauling service to a recovery facility.

On-Site Silver Recovery and Management: The management and treatment of silver-rich solutions on the premises in which the silver-rich solutions are generated.

pH: An expression on a scale from 0 to 14 of the extent of acidity or alkalinity of a substance. Materials with a pH of 7 are neutral. Those below pH 7 are acidic and those above pH 7 are alkaline.

Pollution Prevention: Any practice that reduces or eliminates waste at the source.

POTW: Publically Owned Treatment Works. A wastewater treatment facility (WWTF) owned by the public (municipality or service authority).

Pre-Press: The photographic process used in preparing film and separations.

Preventive Maintenance: A set of procedures routinely performed on equipment and processes to reduce the risk of a malfunction.

Pretreat: To change the characteristic of a waste by treatment before it is discharged to a POTW.

Significant Industrial User (SIU): Any industrial user that: discharges an average of 25,000 GPD or more of process wastewater to a POTW; contributes a process waste stream which makes up 5% or more of the average dry weather hydraulic or organic capacity of the POTW; or, is designated as such by the Control Authority on the basis that the industrial user has a reasonable potential

for adversely affecting the POTW's operation or for violating any pretreatment standard.

Silver Recovery: The process of reclaiming silver from silver-rich solutions such as fixers and low flow washes.

Silver-Rich Solution: A solution containing sufficient silver that cost effective recovery could be done either on-site or off-site. Silver-rich solutions include fixers and low flow wash.

Silver Estimating Test Paper: A test paper coated with an analytical reagent which reacts by changing color in relationship to the amount of silver in solution. A reference color code allows users to estimate the approximate amounts of silver in solution.

Small Commercial Imaging Facility: A facility which produces on average less than 2 gallons per day (GPD) of silver-rich solution.

Source Reduction: A decrease in the production of both the volume and toxicity of liquid waste.

Spill: Unintended release of liquid that is not in the ordinary course of events.

Squeegee: Physical device (e.g. rollers.) used on processors to remove residual surface liquids before the film or paper travels from one processor tank to the next.

Sewer: An underground conduit for carrying wastewater to a POTW.

The Silver Council: A national group supported by the photographic chemical and equipment manufacturers and representing more than 360,000 users whose focus is to achieve source management of silver-bearing photographic imaging materials in the least restrictive regulatory environment.

Appendix B

Electrolytic Silver Recovery

Electrolytic recovery is an efficient and cost-effective silver recovery technology first used in 1931. Since then the equipment has evolved and been refined so that today's electrolytic units are reliable and can consistently achieve 90% recovery efficiency. The equipment is continuously reused and few additional chemicals are required to perform the recovery operation.

B.1 How it Works

Throughout this discussion, refer to the diagram in the right-hand column. In electrolytic silver recovery two electrodes are immersed in silver-rich solution. Electric current reduces the silver-thiosulfate complex in the solution and plates almost pure silver metal onto the cathode—the negatively charged electrode. The cathode is typically made of stainless steel. The amount and quality of the silver plated out depends upon the operating amperage and the length of time the solution is exposed to the current.

There are two basic types of electrolytic equipment: one in which the cathode rotates in the solution and the other in which the solution flows around a stationary cathode. Either type of equipment is capable of recovering a significant amount of the silver from the silver-rich solutions.

In Addition, there are batch units and flow-through units. In the batch unit, the

Electrolytic Unit

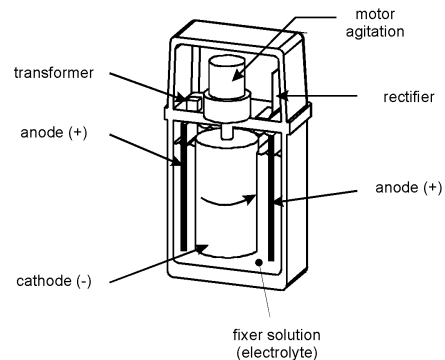

solution is collected within a chamber inside the electrolytic unit until there is sufficient quantity to constitute a batch. The solution is then pumped out all at once, usually into a secondary recovery system. In a flow-through unit, the silver is recovered continuously as it flows into the unit. This solution is displaced as more processor overflow enters the electrolytic unit.

Depending on the percentage removal required, electrolytic units must be used in conjunction with another system.

In-line electrolytic silver recovery

By using in-line electrolytic silver recovery on fix solutions, the amount of silver in solution is significantly reduced. This results in less silver carried over into the final wash water and subsequently discharged to the sewer. Where the use of in-line silver recovery is possible, mixing and chemical usage can be reduced by up to 50 percent, further increasing the cost

effectiveness of this technology. This approach may not be feasible in all circumstances. Solution overflow from in-line systems must be treated by another system to further reduce the silver concentration.

B.2 Proper Operation

The electrolytic unit must have enough capacity to treat peak volumes of silver-rich chemical effluent produced by the printer. The manufacturer/supplier of the electrolytic unit can help the commercial imaging processor choose the appropriate equipment and provide preventive maintenance information. Generally electrolytic unit are monitored for the following: pH; silver concentration; sulfite concentration; time and amperage; and, mechanical operation. All of these are discussed below.

a. pH

Fix solutions from commercial imaging processes are usually easy to desilver electrolytically and require little, if any, pH adjustment.*

b. Silver concentration

The concentration of silver in the overflows from commercial imaging operations will typically range from approximately 2,000 - 4,000 ppm **prior** to electrolytic recovery.

Recovery efficiency is directly related to silver concentration; the higher the silver concentration, the higher the plating efficiency. Replenishment rates play an

important role in determining this concentration level. Over replenishment dilutes the amount of silver. When silver concentration falls below 500 mg/L, plating efficiency decreases significantly thus reducing the recovery rate of the electrolytic unit.

It's very important to calibrate replenishment rates on the processors routinely.

c. Sulfite concentration

In the plating process, for each atom of silver plated out of solution the process consumes one atom of sulfite. It's necessary, therefore, to have sufficient sulfite in the solution. This is particularly important in in-line electrolytic silver recovery where the fix solution is continually recirculated through the processing tank. Any degradation of the fixer can affect the final product. Check with the equipment manufacturer or chemical supplier to find out if you should be using a fix with an increased level of sulfite.

d. Time and amperage

Many of the electrolytic silver recovery units sold today are automatic so the operator doesn't have to set plating current and batch times—two critical factors in electrolytic silver recovery. The correct plating current must be maintained to drive the silver out of solution onto the cathode. If the plating current is too high or the plating time too long, the silver deposited on the cathode will be black and sludgy, with much of it falling off the cathode and collecting on the bottom of

* It is highly recommended not to exceed a pH of 8.5. Above this level significant ammonia air emissions are released.

the electrolytic unit. This situation, known as *sulfiding*, results in a low quality silver and a mess to clean. To avoid sulfiding, follow the manufacturer recommendations for setting both the plating time and amperage.

Attempts to achieve higher efficiencies than those recommended by the manufacturer can actually lead to lower silver recovery. By over extending the plating time or significantly raising the current density, sulfiding will occur. This results in coating the cathode with a black sulfide precipitate rendering it unsuitable for continued silver recovery.

e. Mechanical operation

General mechanical preventive maintenance should be conducted periodically to ensure the plating current is correct, the cathode is rotating or the pump is working, and the color of the silver on the cathode is creamy-grey rather than black or white. The silver should be harvested (removed from the cathode) periodically and sent to the refiner.

The most common mechanical problem with electrolytic units is a poor electrical connection to either the anode or the cathode. It is important that terminals and wires do not come in contact with solutions. Corroded terminals or cables will result in poor plating.

The person who is responsible for silver recovery should follow all manufacturer recommendations for preventive maintenance and keep accurate records of any maintenance performed.

- **Make sure you receive the operations and maintenance manuals for your silver recovery equipment. These manuals are part of the purchase price of your equipment and you are entitled to them.**
- **Obtain data from the silver recovery equipment manufacturer/supplier demonstrating the performance capability of the equipment. For example, if you are required to recover silver to 99 percent efficiency, ask the manufacturer to provide you with data showing the equipment can achieve this level.**

Appendix C

Chemical Recovery Cartridges

Chemical replacement cartridges are a relatively low cost method of achieving a fairly high level of silver recovery.

C.1 How it Works

Metallic replacement is a process that occurs when a solution containing dissolved ions of an active metal such as silver, contact a more active solid metal such as iron. The more active metal, iron which is contained in a cartridge, reacts with the silver and dissolves in solution. The less active metal, silver, becomes a sludge or solid and collects in the cartridge.

In essence, the dissolved silver in solution changes places with the solid iron in the cartridge. The exchange reaction is dependent on the contact of the silver-thiosulfate in solution with the iron surface. To ensure good and controlled contact, metallic replacement is accomplished by metering the silver-rich solutions through a cartridge of iron. As silver is removed from the solution, the iron metal filler in the cartridge becomes depleted. The cartridge is then replaced with a new cartridge and the accumulated silver sludge is sent to be refined.

A typical metallic replacement cartridge generally called a chemical recovery cartridge (CRC) is shown in the diagram on the right.

Chemical Recovery Cartridge

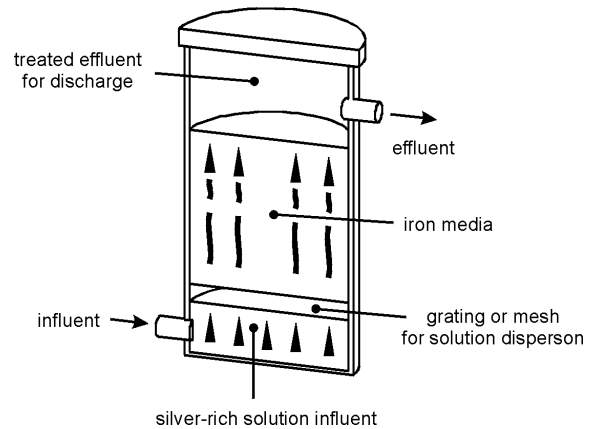

There are a variety of CRCs on the market today. They contain iron in the form of chopped steel wool, spiral wound steel wool, a heavy iron mesh similar to door screening material, or iron chips imbedded into a fiberglass support.

A properly designed and maintained single-cartridge CRC system is capable of recovering more than 95 percent of the silver from silver-rich solutions when used in accordance with manufacturer specified flow rates. A two-cartridge system is capable of recovering 99 percent of the silver.

Where the flow of solution through the cartridge exceeds its rated capacity, flow control must be used. While a metering pump is generally recommended, in extremely low volume situations, a flow restrictor may be adequate.

C.2 Operation/Maintenance

The manufacturer/supplier of the CRC can help the photo processor choose the appropriate equipment. This is also the best source of preventive maintenance information. Generally chemical recovery cartridges are monitored for the following: flow rate; channeling; obstruction; pH; and, cartridge capacity.

a. Flow rate

The length of time the silver-rich solution is in contact with the iron is critical for effective silver recovery. If the solution flows through the CRC too quickly, it will not contact the steel wool long enough for the iron/silver reaction to occur. The lower the flow rate, the better the recovery.

A pump or restricted orifice is used to meter the solution at a prescribed rate from the holding tank to the first CRC in the series. To ensure proper flow rate, calibrate the metering pump each time the CRCs are replaced. Consult the manufacturer for the optimum flow rate.

b. Channeling

As the recovery cartridge is used, the active surface area is used up and small channels will begin to develop in the iron material. This is known as channeling. It also occurs when a CRC is used only intermittently due to low volume. When a small volume of solution enters the CRC and sits on the surface, it slowly eats through the steel wool, forming a vertical shaft or channel as it goes. As more solution enters the CRC, it takes the path of least resistance and flows through the channel, thus contacting very little of the steel wool in the cartridge. This causes

only a small amount of the iron to be used (that along the channel). When channeling occurs, only low levels of silver are recovered and high levels are discharged from the CRC.

To avoid channeling: (1) select the proper size CRC for the average volume of film and paper processed in your lab, and (2) prefill the CRC with water just prior to introducing chemical solutions into it.

c. Obstruction

When the iron in solution contacts air, iron hydroxide or rust forms. If the rust is allowed to build up in the lines leading into and out of the CRCs, it can eventually restrict the flow of solution causing the solution to back up. The CRC may also leak around the fittings and cover.

Obstruction also occurs when the center core of the CRC is crushed or damaged and the solution cannot pass through it. If this happens, replace the CRC with a new one. Consult the CRC supplier for information.

Finally, rust that passes through the CRC can eventually build up in the floor drain, requiring expensive drain cleaning.

Monitor the system regularly for obstruction. Remove the lines and rinse them with hot water each time the CRCs are replaced. Do this more often if there are several hours each day when no solution is flowing through the CRCs. Be sure to run the overflow system downhill so there's no chance of back-up.

To reduce the possibility of rust in the lines, make a loop in the line that will create an airlock.

d. pH

For best results with CRCs, the pH should be between 4.5 to 5.5. If the pH is too low, the steel wool is etched too quickly reducing the life of the CRC. If the pH of the solution is too high, etching does not occur so the silver/iron exchange reaction can't take place. Also, at higher pH levels, iron hydroxide (rust) is formed which can cause obstructions in the lines and drains.

Try to maintain a consistent pH in the influent going to the CRCs. This is best accomplished by plumbing the silver-rich overflow directly from the processors to the silver recovery system. Typically the pH of commercial imaging fixers are between 4.5 and 6.5, and will not require pH adjustment. Work with your equipment supplier to determine the best pH for your CRCs.

e. Cartridge capacity

Each type of CRC has a limited capacity to recover silver depending on the type and amount of iron. Manufacturers generally rate the capacity of their CRCs in both gallons of solution and time. For example, depending on the silver concentration of the solution going in, a CRC might have the capacity to desilver 100 gallons of solution or last 12 weeks, whichever comes first. Ask the manufacturer to help you in selecting CRCs appropriate for your lab.

Keeping a log

Keep a silver recovery log to record all of the checks and testing you do on your silver recovery equipment. As soon as the weekly check (done with silver estimating test papers) shows color, you know the chemical recovery cartridge has failed and it's time to change it. When you install a

new CRC, mark the installation date on the cartridge.

Check with your local POTW authorities to find out how long to keep these records on file.

Blank silver recovery log forms are provided in Appendix H. Make copies of these forms when you need them. Keep the originals in this Guide.

The person who is responsible for silver recovery should follow all manufacturer recommendations for preventive maintenance and keep accurate records of any maintenance performed.

- **Make sure you receive the operations and maintenance manuals for your silver recovery equipment. These manuals are part of the purchase price of your equipment and you are entitled to them.**
- **Obtain data from the silver recovery equipment manufacturer/supplier demonstrating the performance capability of the equipment. For example, if you are required to recover silver to 99 percent efficiency, ask the manufacturer to provide you with data showing the equipment can achieve this level.**

Appendix D

Off-Site Management

The following information applies only to commercial imaging operations that ship waste off-site.

In some situations, off-site silver recovery is the best option. For example:

- Commercial imaging operations required to meet excessively restrictive silver concentration limits may be forced to ship the solutions off-site for treatment.
- If an imaging operation produces less than one gallon of silver-rich solution/day, a chemical recovery cartridge may oxidize and channel long before the iron is exhausted. This may create more waste than it prevents.
- For commercial imaging operations discharging to a septic tank and leach field, there is no option; they must haul.

Commercial imaging processing chemicals must not be discharged to septic systems. This could cause an upset that would destroy the microorganisms responsible for breaking down the waste water.

F.1 Off-Site Requirements

Solutions containing 5 mg/L or greater of silver are currently classified as hazardous waste. In order to transport these solutions off-site, the facility must fulfill the requirements for transporting hazardous waste. In this section, we're going to discuss the Federal requirements for off-site silver recovery. Since individual states may enact stricter regulations,

make sure you check with your state agency for its specific requirements.

a. Generator category

If you're shipping off-site waste pre-press processing solutions containing 5 ppm or more of silver, it's important that you know how to determine your hazardous waste category. This category is based on the total amount of hazardous waste produced by your company. The specific requirements for accumulation, storage, and manifesting vary depending on the category.

The chart on the next page shows the three categories established in the federal Resource Conservation and Recovery Act (RCRA). These categories, as shown across the top of the chart, are:

- Conditionally exempt small quantity generator
- Small quantity generator
- Large quantity generator

To determine your category, track the monthly volume of hazardous waste including waste processing solutions containing 5 ppm or more of silver produced in your facility to be sent off-site.

For example, if you process film in several locations within your facility and the solutions are accumulated and taken off-site, add all the fixer produced in all locations for one month. If it's less than

Hazardous Waste Category*		
<i>Conditionally Exempt Small Quantity Generator (CESQG)</i>	<i>Small Quantity Generator (SQG)</i>	<i>Large Quantity Generator (LQG)</i>
Facility that produces less than 100 kilograms per month of hazardous waste	Facility that produces more than 100 but less than 1,000 kilograms per month of hazardous waste	Facility that produces more than 1,000 kilograms per month of hazardous waste
<p>* Any photo processing waste containing 5 ppm or more of silver is considered hazardous under the Resource Conservation and Recovery Act (RCRA). Most states and municipalities have additional regulations for discharge and transport of silver and silver-bearing wastes. For more information contact your local state hazardous waste agency.</p>		

100 kilograms (approximately 220 pounds or 25 gallons), your facility falls into the category of conditionally exempt small quantity generator.

b. Generator identification number

SQGs and LQGs must obtain an EPA identification number before shipping waste off-site. This 12-character number identifies both your site where the waste is produced and the type of waste. It's a key element of tracking the waste from *cradle-to-grave*. Your state hazardous waste agency can provide you with the proper paperwork.

In some states, CESQGs do not have to obtain an ID number.

c. Accumulation and storage

CESQGs must never accumulate more than 1000 kilograms (kg) of waste at any time. (1000 kg is approximately 300 gallons).

SQGs must never accumulate more than 6000 kg of hazardous waste in any 180

day period. (6000 kg is approximately 1600 gallons).

LQGs must not accumulate hazardous waste on-site longer than 90 days.

In all cases, wastes must be stored in tanks and containers suitable for commercial imaging processing waste. In addition:

- Clearly mark each container with the words *Hazardous Waste* and with the date you began to collect waste in that container.
- Use only containers in good condition.
- Keep containers closed except when you fill or empty them.
- Inspect areas where containers are stored, at least weekly, looking for leaks and deterioration.
- Provide secondary containment where it's required.

HAZARDOUS WASTE	
Federal Law Prohibits Improper Disposal If found, contact the nearest police or public safety authority, or the U.S. Environmental Protection Agency	
Accumulation Start Date: Jan 12, 1997	EPA Waste #: D011
Generator Name: Mr. Opaque Pre-Press Ltd.	
Address: 1500 Main Street	
City: Your Town	State: NY Zip Code: 02143
EPA ID #: XX9876543210	Manifest #: 554332
DOT Proper Shipping Name, Class, UN#, and packing group: RQ Hazardous waste liquid, n.o.s. (silver), Class 9, NA 3082, Packing group III	

d. Labels and marks

Containers of silver-rich chemicals must be properly labeled and marked. The label shown above contains the six required elements:

1. accumulation start date,
2. EPA waste identification number,
3. site name and address where the waste was produced (generator name),
4. EPA generator identification number,
5. manifest number, and
6. Department of Transportation (DOT) shipping name for the waste.

e. Manifests

The manifest is a multi-copy document used to track the waste from the time it leaves the producer (the commercial imaging facility), to the time the receiver treats, recycles or disposes of it. Each party in the link—producer, transporter, receiver—have EPA identification numbers and each must complete its portion of the manifest.

The producer is responsible for obtaining numbered manifest forms from the state hazardous waste agency. All links in the chain keep a copy of the manifest and receive copies from the other links to acknowledge receipt of the waste. Manifests must be kept on file by the producer for at least three years. Manifests are not required for CESQGs. Some transporters, however, may still ask they be used to help the transporter and receiver fulfill their requirements.

f. Spill response and training

SQGs and LQGs are required to develop emergency plans and train employees on emergency response so that if a spill or accident occurs, the facility is ready. Generally, the plans must include procedures and identify the necessary spill control/response equipment.

F.2 Precautions

One important element of the *cradle-to-grave* waste management system is liability. Once you've produced the waste, you retain some responsibility even after turning it over to a licensed transporter and a licensed receiver. This means you must choose your waste management partners carefully.

Talk with your colleagues, trade associations and state hazardous waste agency to get the names of licensed companies that could handle silver-bearing processing wastes. Choose a firm with a good reputation. Verify their EPA identification numbers and any required permits. Keep copies of their permits on file. Visit their site to look at their equipment and the general condition of their operation. Choose carefully and with confidence.

Appendix E

Evaporation/Distillation

Evaporation and distillation are generally used in conjunction with off-site management. These processes reduce the volume of effluent to be taken off-site for treatment and disposal. When the off-site management costs are based on the volume of solution, evaporation and distillation may help to reduce costs.

E.1 How it Works

Because evaporation releases fumes to the air, permits are often required to operate an evaporator. Hazardous waste permits may be required. Most equipment used today consists of both evaporation and distillation where the water vapor is boiled-off, captured and condensed and the fumes are contained.

In distillation, the liquid portion of the process overflow is heated to its boiling point. Then the vapors are captured and cooled resulting in a distillate of essentially distilled water that can be discharged to the drain or used to mix fixers. Since the distillate contains ammonia and sulfite, using it to mix developers is not generally recommended.

Depending upon the unit, 80 to 100 percent of the water is removed leaving a silver-rich slurry or solid to be managed off-site as a hazardous waste.

Evaporation/Distillation Unit

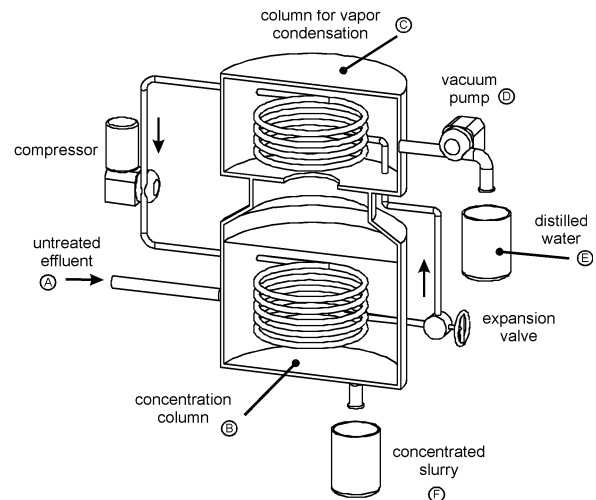

E.2 Proper Operation

Routine cleaning of the evaporation or distillation unit is the most important preventive maintenance operation. Dried chemistry and dust can easily accumulate reducing the performance of the equipment. Intake and overflow screens along with air filters must be checked and cleaned periodically. The distillation chamber should be inspected and cleaned.

Appendix F

Ion Exchange

Ion exchange technology can be used to recover silver from dilute processing solutions and wash waters. Keep silver levels as low as possible in wash water by preventive maintenance of the equipment and monitoring replenishment rates.

Ion exchange is recommended for use only to remove silver from some *low-silver solutions* (<1 percent) such as wash water. It is *not generally* recommended for use with fix solutions.

G.1 How it Works

Ion exchange is a reversible exchange of ions between a solid (resin) and a liquid (water containing ionized salts). When ion exchange is used with low-silver solutions, the silver thiosulfate in solution is adsorbed to the resin in the column. Periodically, under a service contract, the column is removed and the resin is rinsed with a dilute sulfuric acid solution to decompose the silver thiosulfate to silver sulfide, which remains in the ion exchange column. The resin is reused for many cycles and is then incinerated to recover the silver accumulated in it.

Ion exchange should not be used for recovering silver directly from silver-rich fix solution.

These concentrated thiosulfate solutions will strip silver from the resin, and can

Ion Exchange Column

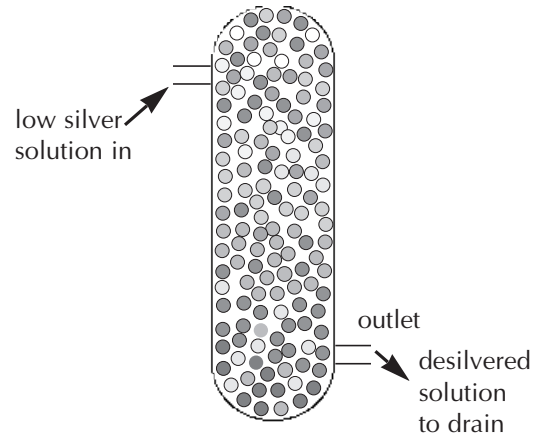

actually result in *more* silver being discharged from the resin column than is present in the feed solution. Ion exchange, therefore, lends itself only to the recovery of silver from wash waters and dilute processing solutions. Typically, more than 90 percent of the silver from wash waters can be removed in a single-column system. Two-columns used in series can provide 99 percent silver removal efficiency.

G.2 Proper Operation

Converting equipment to incorporate in-line silver recovery greatly reduces the silver content of the final wash water. Ion exchange technology is most effective when used in conjunction with an in-line silver recovery unit for the preceding fixer solution.

Factors affecting the efficiency of ion exchange include:

- thiosulfate concentration,
- flow rate, and
- biological growth control.

a. Thiosulfate concentration

The capacity of the resin to retain silver is very dependent on the concentration of thiosulfate in the influent. The higher the thiosulfate, the lower the capacity. That's why ion exchange is not recommended for recovering silver from fix. These solutions are high in thiosulfate.

If you operate under such severe discharge restrictions that you must use ion exchange to recover silver from silver-rich solutions, two steps are required:

1. desilver the silver-rich solutions through an electrolytic unit, and
2. meter the desilvered solutions into the collected wash water overflow at a rate not exceeding their replenishment rate.

These procedures will reduce the silver concentration prior to ion exchange and ensure the thiosulfate levels are controlled.

b. Flow rate

The low-silver solutions must be metered through the ion exchange columns at a prescribed rate in order to allow for the exchange between the silver and the resin to occur. Generally, this should never exceed 1 bed volume of resin/minute.

c. Biological growth control

Algae, bacteria and fungi grow quite readily in ion exchange columns and feed on the dilute photographic processing chemicals. This growth causes two problems: 1) it forms a film on the resin beads, thereby blocking the silver exchange reaction, and 2) it obstructs the flow of solution through the column.

To eliminate the problem of biological growth, the ion exchange column(s) must be flushed routinely with biocide.

Appendix G

Testing for Silver

You must routinely monitor your silver recovery system to make sure it's operating correctly. There are two different testing methods required: approximations utilizing test papers are performed frequently and exact analytical testing is performed every three months, six months or annually, depending on the size of the commercial imaging facility.

H.1 Silver Estimating Test Papers

Silver estimating test papers are used to provide only an *approximation* of how much silver is in a solution. The test strips are coated with yellow cadmium sulfide that forms brownish-black silver sulfide when it comes into contact with silver ions. The higher the concentration of silver in solution, the greater amount of brownish-black silver sulfide will be formed. The color formed on the test strip after it has been in solution, therefore, reflects the amount of silver contained in that solution.

Generally, the procedure for using the test strips is as follows:

1. Dip the test strip in the sample solution for two (2) seconds so that the strip is properly wetted.
2. Remove the test strip from solution, shake off any excess liquid, and place the strip on a white card.

3. After about 15 seconds, compare the color on the moist test strip with the color key provided with the test strips. Find the color that most closely matches. That is approximately the concentration of silver in solution.
4. When evaluating a solution that has color, such as seasoned fixer, rinse the test strip briefly under running water toward the end of the 15-second waiting period. Take the color of the solution into consideration when you're making the comparison with the color key.

A typical color key scale is shown below. As you can see from the scale of numbers ranging from 0 to 10 g/L* (0 - 10,000 mg/L), the silver readings are only approximations of the actual silver in solution. Note that the lowest detection point is .5g/L or 500mg/L (500 ppm).

The test strips are helpful in *estimating* the amount of silver in the solution exiting the silver recovery system. Once the solution has gone through primary silver recovery,

* Silver estimating papers are generally scaled in grams per liter (g/L) rather than parts per million (ppm). Remember: mg/L and ppm are the same measurement.

the concentration of silver should be below the 500 mg/L (ppm) mark. Since the lowest range on the silver estimating test papers is 500 ppm, you should see no color change on the paper. **These papers are only useful for finding major problems with the silver recovery system.**

For example, if you are using chemical recovery cartridges, you are required to test the cartridge effluent using test strips to determine the presence of silver. **The effluent should be below 500 ppm and therefore, not change the color of the test strip.** The only thing you've learned from testing the effluent with a test strip is that there are no major problems with the chemical recovery cartridges. A more exacting measurement must be taken periodically to verify the system is actually recovering the percentage of silver required.

H.2 Analytical Testing

An exact analytical measurement is required to verify whether the silver recovery system is achieving a specific percentage recovery. Use an outside analytical laboratory to analyze the solution samples.

Obtain a sample bottle from the analytical laboratory, fill the bottle with a sample of the solution to be analyzed and bring the bottle to the laboratory. When they have finished the procedure, the analytical laboratory will provide the results of the analysis.

Your best source of information concerning your sampling procedures and techniques is the analytical lab that's doing your work. Work with them closely to get your best results. Here are some general considerations for sampling:

a. Sample containers

- Obtain plastic containers from the analytical laboratory. Don't use glass because silver precipitates more easily on the wall of a glass container.
- Make sure the laboratory knows that you are specifically testing for silver so they provide you with the correct size and type of container.

b. Sample preservation

- Tell the analytical laboratory NOT to use a nitric acid preservative with the sample. Nitric acid precipitates the silver out of solution, thereby providing an artificially low silver reading.
- Return the sample to the analytical laboratory as quickly as possible to avoid any change in the make-up of the sample.

c. Sampling methodology

- Rinse the sample bottle with the sample once or twice before filling it for analysis.
- Make sure that none of the equipment you are using to collect the sample has been contaminated with another solution or material.

d. Analytical test methods

There are two methods the analytical laboratory can use to detect silver in the sample:

1. Inductively coupled plasma spectroscopy (ICP)
2. Atomic absorption (AA)

Either test will provide the same result.

Appendix H

Forms

SPILL CONTINGENCY PLAN

Spill Response Personnel

Name _____ pager/phone _____

Name _____ pager/phone _____

Name _____ pager/phone _____

**Environmental
Emergency
Phone**

(999) 999-9999 24 hours a day
7 days a week

EQUIPMENT REQUIRED

- Gloves
- Apron
- Goggles
- Bucket
- Mop
- Sponge
- Absorbent Materials
- Neutralizing Materials

SPILL RESPONSE PROCEDURES

1. Put on gloves, goggles and an apron.
2. Contain the spill with a mop or absorbent materials available.
3. Check the appropriate material safety data sheet (MSDS) for special handling, ventilation, personal protection or other pertinent data.
4. Clean up the spill, as directed, using generous amounts of water.
5. Use the mop and sponge to clean the area thoroughly.
6. Package and label all contaminated absorbent materials for off-site disposal.
7. Notify the supervisor or manager that a spill has occurred.
8. (If required) Notify appropriate government agency that a spill has occurred.

* This plan will *not* meet the requirements in all states, including California.

Worksheet for Screening Options

Date _____

Option: _____

1. What is the potential for reducing waste and providing other environmental benefits?

2. What is it going to cost in time and materials?

3. How much money will it save in time and materials?

4. How difficult is it to implement?

Pollution Prevention Plan Worksheet

Date _____

Option or activity: _____

Implementation date: _____

Responsibility: _____

Record: _____

Pollution Prevention Plan Worksheet

Date _____

Option or activity: _____

Implementation date: _____

Responsibility: _____

Record: _____

Worksheet for Evaluating P2

Date _____

Option: _____

1. Waste reduction results _____

2. Costs _____

3. Savings _____

Worksheet for Evaluating P2

Date _____

Option: _____

1. Waste reduction results _____

2. Costs _____

3. Savings _____

